

# Chapter 1

## Compton scattering as a beam diagnostic: Laser-wire

The beam delivery section of the International Linear Collider (ILC) [1] will be used to tune high intensity beams with high accuracy to focus them to the nanometric size required at the interaction point. To achieve such tight focussing at the interaction point, the beam size will have to be known in the beam delivery line with micrometer accuracy<sup>1</sup>. Neither screens nor conventional wire-scanners are able to sustain such high flux while giving such small resolution. A proposed solution would be to use a laser-wire instead of a wire-scanner.

In a laser-wire, a tightly focussed high-power laser beam crosses an electron beam. The Compton scattering that occurs is proportional to the number of electrons across the laser path. By moving the laser beam it is possible to measure the transverse profile of the beam with an accuracy corresponding to the size of the laser beam in the interaction area.

This technique has been pioneered at the SLC [2]. A variant of it has been tested at high power  $H^-$  accelerators such as the SNS [3] and the ISIS Test Stand in the UK [4]. For  $H^-$  machines, the physical process involved is photodissociation instead of Compton scattering.

In 2004, I joined a R&D group to demonstrate the feasibility of a laser-wire for the ILC. Our aim was to demonstrate the possibility of scanning the ATF extraction line beam with micrometer resolution.

---

<sup>1</sup>To focus a beam to such a small size requires first to demagnify it to large sizes and control very accurately this size and the associated optical function until the final focussing element where the size is significantly reduced. Such technique allows to minimize the aberration at the focal point and is applicable to both electrons and photons.

## 1.1 Large aperture lens design

One of the key points of this experiment was the design of a lens capable of giving a diffraction limited (or almost) spot at the interaction point. In addition this lens had to include as one of its optical elements a fused silica window (to allow the transition between air and the accelerator vacuum) and be radiation hard. The radiation hardness required the use of only fused silica (although test made later have shown that optics made of another glass, BK7, have a good lifetime under radiation as well and thus could have been used). As the lens had to be outside the vacuum it had to have a long focal lens (longer than 24 mm).

The solution chosen at SLC of using a parabolic mirror inside the vacuum was rejected as this did not allow scanning the laser beam sufficiently fast for the ILC requirement (the SLC laser-wire scanned the beam by moving the chamber vertically).

I designed such lens using the ZEMAX [5] Optical Design Software and documented it in [6]. Only its main features (taken from [6]) are described here.

This lens is made of three elements: the first element has an aspheric surface and a spheric one. The second element has two spheric surfaces. The last element is flat and is used as a window to allow the laser light to enter the beam pipe. All these elements are made of top-quality fused silica. Beam dynamics and mechanical considerations require the inner side of the window to be more than 20 mm away from the interaction point (IP) that must be roughly in the centre of the beam pipe. In this design this inner surface of the window is 24 mm away from the IP. The window has a thickness of 12.7 mm. The position of the two other elements is constrained by mechanical and cost considerations: to allow the sealing of the window these two elements must be more than 14 mm away from the window, but they must be kept as close as possible to the window to limit their size (and hence their cost). In our design one of these elements is located 18 mm away from the window and has a thickness of 5.3 mm. The second element (aspheric) is located 2 mm further away and has a thickness of 7 mm. The layout of this lens and the energy distribution from the centroid are shown in figure 1.1.

As only fused silica could be used, the lens could not be achromatic and it was designed to work with frequency doubled Nd:YAG lasers (532 nm).

One of the difficulties with this design is that each surface can also act as a reflective mirror. This is especially true with the input window as it is flat. Given that this lens was designed to be used with a high power laser we wanted to avoid any ghost focus inside the glass element. However after several attempts we did not find any reasonable solution and therefore we settled for a design with a second order ghost with a diameter of 500  $\mu\text{m}$  in the first element as shown on figure 1.2. Our calculation showed that this ghost would not be an issue at the design power. After several year of operation these predictions have proven true.

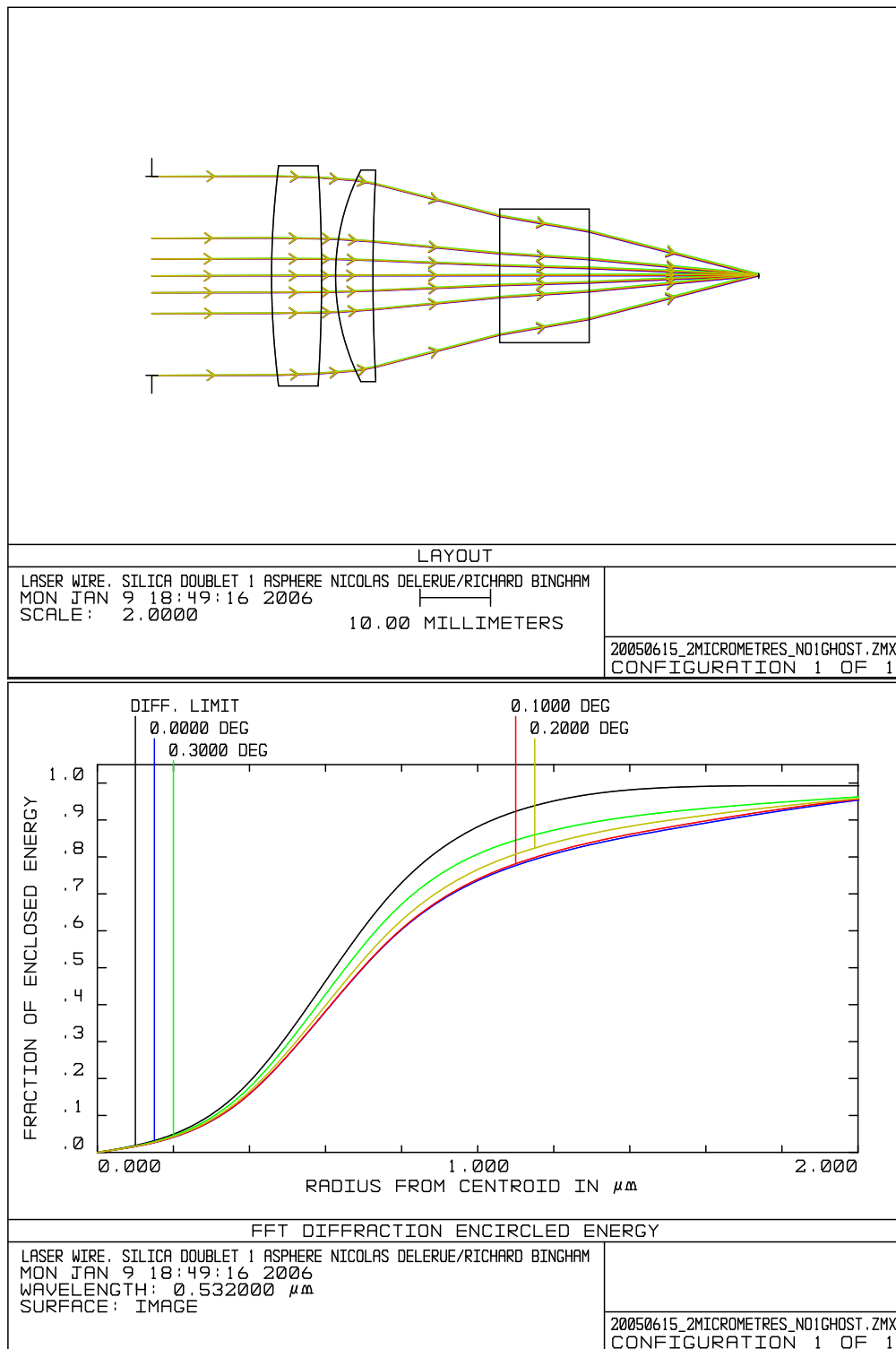

Figure 1.1: Laser-wire lens doublet design (top) and energy distribution from the centroid (bottom). The upper (black) line shows the diffraction limit, the 4 other lines show the real value when the incoming laser beam has a tilt of 0 degree (blue), 0.1 degree (red), 0.2 degrees (yellow) and 0.3 degrees (green). Images taken from [6].

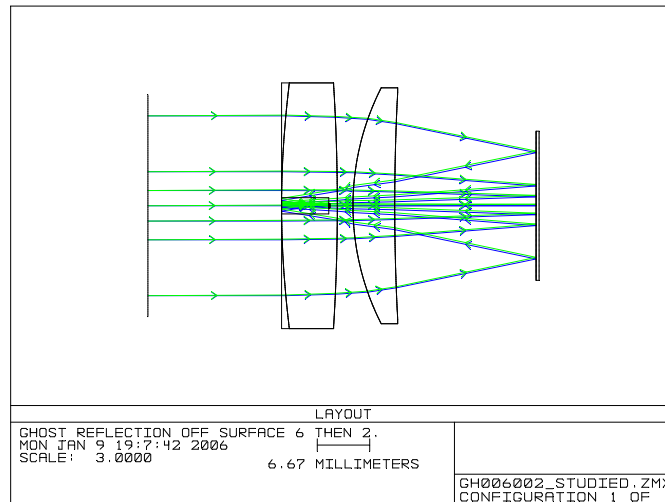

Figure 1.2: This ghost reflection of the lens focus is formed by a reflection on the outer surface of the vacuum window and on the aspherical surface.

## 1.2 Experiment at the ATF

The lens was part of an experiment that I coordinated with the aim to install a laser-wire in the extraction line at the ATF at KEK in Japan. The experiment is detailed in [7]. The main novelty of the experiment was to be able to scan with a micrometer resolution thanks to the lens described above. The system also had to be compatible with ultrafast scanning (kHz rate) to allow a bunch profile measurement in a single train at the ILC although we used a slower system at the ATF as the repetition rate was only 1.65 Hz. A description of the ATF can be found in [8].

The experiment was installed in a bend of the ATF extraction line to allow an easy extraction of the  $\gamma$  rays produced by Compton scattering. The layout of the ATF extraction line with the location of the laser-wire is shown in figure 1.3. The laser was installed above the extraction line and a telescope brought the laser radiation near the IP. An optical table allowed to measure the laser properties near the IP. Some laser diagnostics were also installed after the IP to monitor the laser during data taking. The laser delivery layout is shown on figure 1.4. A calorimeter was located behind a bending magnet to measure the  $\gamma$  rays produced.

One of the main difficulty for this experiment was to cross the beam in space and in time. As the laser beam had by design a very small size it was very difficult to find the overlap between the two beams. One of the lessons I learned from this experiment is that we should have kept the possibility of defocussing the laser at first (for example with a lens on a translation stage) to have a larger laser spot size while trying to adjust the other parameters (especially the laser timing with respect to the electron bunches arrival time).

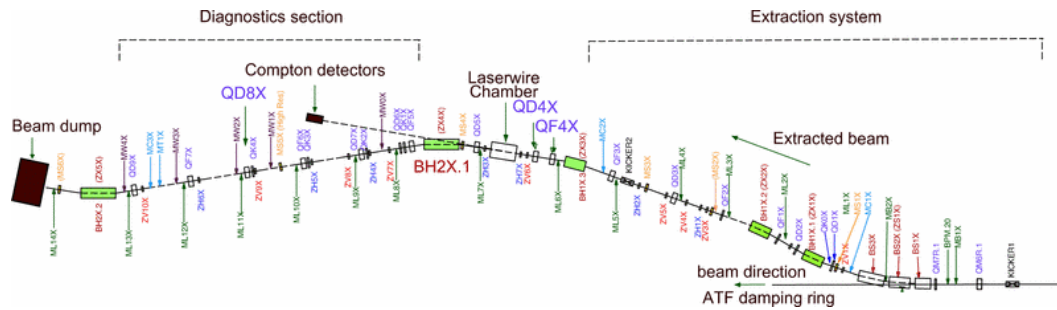

Figure 1.3: Layout of the ATF extraction line showing the location of the laser-wire. Image taken from [7].

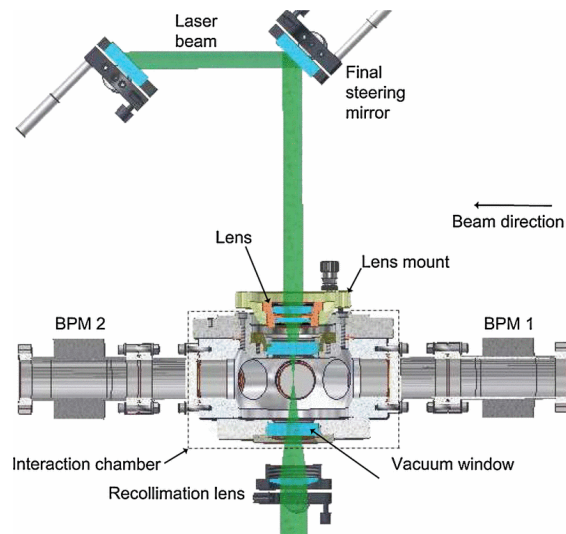

Figure 1.4: Experimental layout of the laser-wire installed in the ATF extraction line. Image taken from [7].

### 1.3 High repetition rate laser

Another key point in the laser-wire R&D was to demonstrate that a laser suitable for the needs of the ILC could be built. The power of this laser had to be chosen so that a sufficient number of  $\gamma$  photons would be produced at each collision to allow fast scanning of the beam. However the beam quality had to be good enough to give a micrometer resolution and, given the chromatic constraints of the lens discussed above, it had to have a narrow wavelength bandwidth. The requirements of this laser have been summarized in [9]. I was in charge of the technology choice for this laser.

My calculation showed that we needed about 10 MW of laser power with a pulse duration of 1 ps. One of the limiting factors was the specific repetition rate required: to match the ILC repetition rate the laser had to produce burst of pulses at a pulse repetition rate of 6.5 MHz (or 3.25 MHz) during 900  $\mu$ s at a train repetition rate of 5 Hz.

Several technologies were available to us. The most mature technology to give high power is clearly Ti:Sa. Back in 2006 I visited factories in the US where several Ti:Sa lasers were being assembled at the same time. At the time such large production line did not exist for the other technologies (or at least not with the suppliers we visited).

However the mode quality offered by suppliers of Ti:Sa lasers was not as good as that of Nd:YAG or Nd:YLF lasers. During the process of the technology choice we paid particular attention to Ytterbium fibers lasers (already discussed in section ??). Although that technology was not as mature as Ti:Sa or Nd:YLF, it had a clear potential and we were confident<sup>2</sup> that it would reach maturity on the timescale of the construction of the linear collider<sup>3</sup>. So at the end, we decided to choose a fiber laser from Amplitude Systèmes with some developments to be done together [10].

The scheme on which we converged was to buy a commercial laser oscillator and to build the amplifier ourselves, taking advantage of the recent developments of photonics crystal fibers to achieve the power required. This development was not complete when I left Oxford but it was on a good path [11].

### 1.4 Undefined references

chap:plasmaAccelerationMechanism chap:pepper-pot chap:SP chap:thomx sec:thomxsynchro  
sec:ESCU LAP

---

<sup>2</sup>And 6 years later I visited in France production lines of fibers lasers that were comparable to those I had seen earlier in the US for Ti:Sa lasers.

<sup>3</sup>Back in 2006, it was expected that the ILC would be built before 2020.

# Bibliography

- [1] Avinash Puntambekar et al. ILC Reference Design Report: ILC Global Design Effort and World Wide Study. 2007.
- [2] R Alley, D Arnett, E Bong, W Colocho, J Frisch, S Horton-Smith, W Inman, K Jobe, T Kotseroglou, D McCormick, J Nelson, M Scheeff, S Wagner, and M.C Ross. Proceedings of the sixth international conference on instrumentation for experiments at e+ e- colliders a laser-based beam profile monitor for the slc/sld interaction region. *Nuclear Instruments and Methods in Physics Research Section A: Accelerators, Spectrometers, Detectors and Associated Equipment*, 379(3):363 – 365, 1996.
- [3] Y. Liu, A. Aleksandrov, S. Assadi, W. Blokland, C. Deibele, W. Grice, C. Long, T. Pelaia, and A. Webster. Laser wire beam profile monitor in the spallation neutron source (sns) superconducting linac. *Nuclear Instruments and Methods in Physics Research Section A: Accelerators, Spectrometers, Detectors and Associated Equipment*, 612(2):241 – 253, 2010.
- [4] David Lee, Jürgen Pozimski, Peter Savage, and Christoph Gabor. A Laser-Based Beam Profile Measuring Instrument for the Front End Test Stand at RAL. In *Particle accelerator. Proceedings, 23rd Conference, PAC'09, Vancouver, Canada, May 4-8, 2009*, page TH5RFP051, 2010.
- [5] Zemax LLC. Zemax, optical design software. <http://www.zemax.com>.
- [6] Nicolas Delerue et al. Status of the ATF extraction line laser-wire. 2005.
- [7] Stewart T. Boogert, Grahame A. Blair, Gary Boorman, Alessio Bosco, Lawrence C. Deacon, Pavel Karataev, Alexander Aryshev, Masafumi Fukuda, Nobihiro Terunuma, Junji Urakawa, Laura Corner, Nicolas Delerue, Brian Foster, David Howell, Myriam Newman, Rohan Senanayake, Roman Walczak, and Fred Ganaway. Micron-scale laser-wire scanner for the kek accelerator test facility extraction line. *Phys. Rev. ST Accel. Beams*, 13:122801, Dec 2010.
- [8] J. Urakawa et al. Recent Results on KEK/ATF Damping Ring. In *Proceedings, 17th International Conference on High-Energy Accelerators, HEACC 1998: Dubna, Russian Federation, September 07-12, 1998*, pages 117–119, 1998.

- [9] S. Dixit et al. A study of laser system requirements for application in beam diagnostics and polarimetry at the ILC. *Conf. Proc.*, C060626:741–743, 2006. [,741(2006)].
- [10] Y. Zaouter, E. Mottay, L. Corner, and N. Delerue. Ultrafast amplified fiber laser for laser-wire measurements in particle accelerators, 2008.
- [11] Laurence Nevay, Grahame A. Blair, Stewart Boogert, Laura Corner, Nicolas Delerue, David Howell, Myriam Newman, Roman Walczak, and Benjamin Rosenberger. Development of a Photonic Crystal Fibre Laser Amplifier for Particle Beam Diagnostics. In *Particle accelerator. Proceedings, 23rd Conference, PAC'09, Vancouver, Canada, May 4-8, 2009*, page TH5RFP098, 2010.