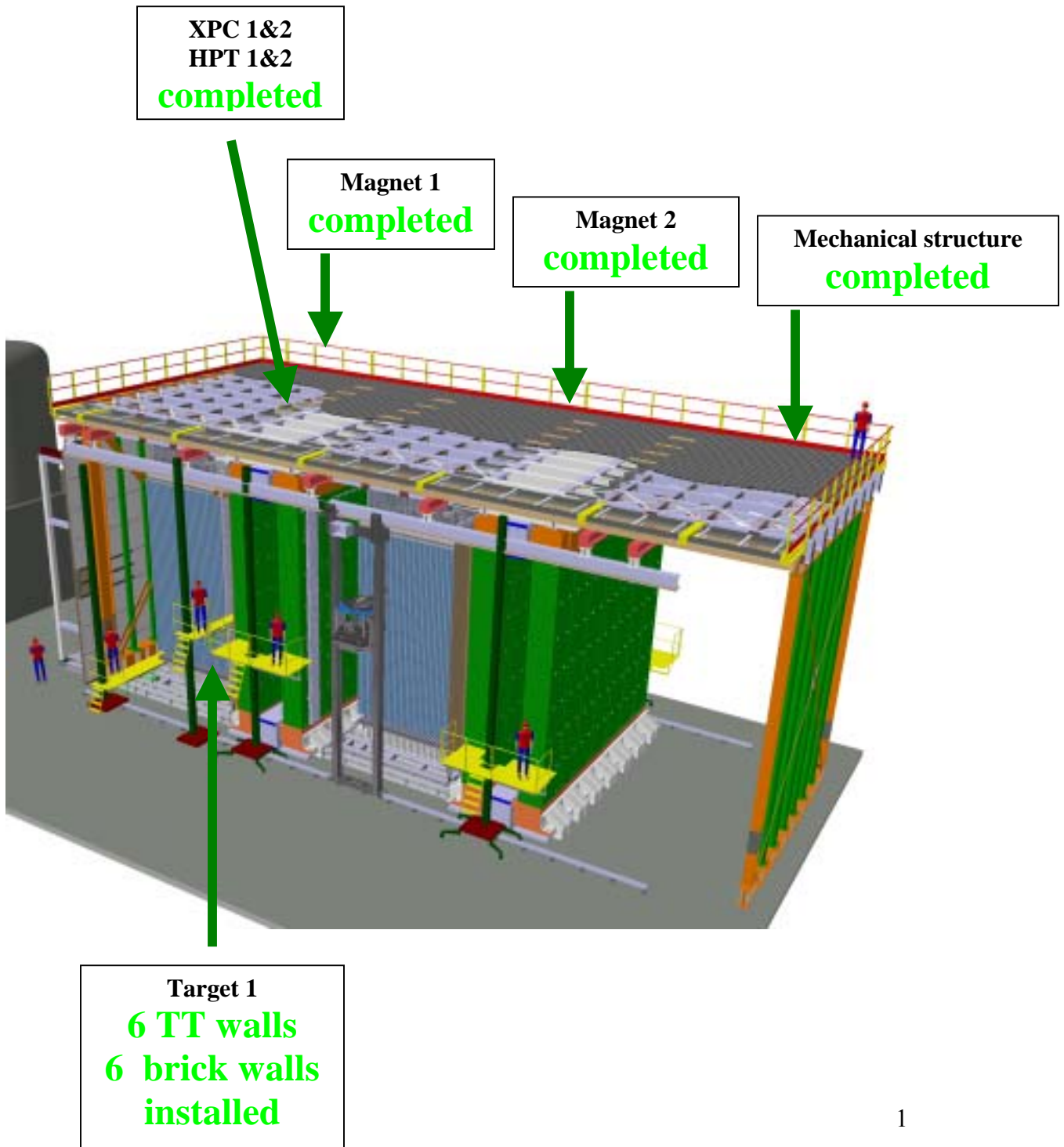




# Installation of the OPERA experiment Status report





HallC activities



Target installation



TT assembly stage



Magnet 2 cabling



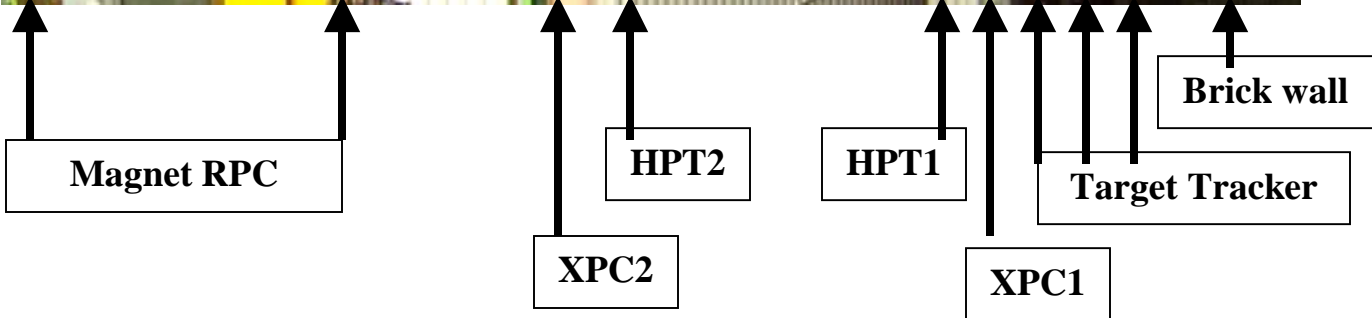
## Table of contents

- 1) **Spectrometer installation status**
  - a) Magnet
  - b) RPC
  - c) XPC
  - d) HPT
  
- 2) **Target installation status**
  - a) Positioning and alignment
  - b) Pitch change for the target
  - c) Target Tracker
  - d) Brick wall
  
- 3) **DAQ**
  
- 4) **Brick preparation and handling**
  - a) Lead
  - b) Emulsions
  - c) Changeable sheet
  - d) BAM
  - e) BMS
  - f) Emulsion processing at LNGS
  - g) Scanning
  
- 5) **Computing**
  
- 6) **General schedule**
  
- 7) **Physics performance and Tests results**
  
- 8) **Funding issues**
  
- 9) **Human resources**



# 1) Spectrometer Installation

Top coil  
↓







## 1-a: Magnet



### Installation

The alignment of the vertical slabs was validated during the installation phase and no relevant difficulties have been experienced during the positioning of the upper return yokes. All diagnostics for the magnetic field embedded in the spectrometer are now positioned (pick up coils between the vertical slabs and Hall probes) together with temperature sensors. The mounting of the upper return yokes allowed the completion of the OPERA support structure between SM1 and SM2. Moreover, the lower half of the upper coil and the corresponding heat exchanger was completed by May 2005 (see Fig.1). The installation of the rear support structure of OPERA between SM2 and the back arch is in progress together with the installation of the upper coil. In particular, the support for the area housing the pumps and heat exchangers for the water cooling system (see below) will be in position by summer 2005.

### Power supplies

The construction of the power supplies (PS) for the magnets is in progress. High and low power electronic component have already been acquired by the supplier. The final drawings of the mechanics are available while the drawing for the electric parts are expected by July 2005. Prototype tests of the main units have been completed in June 2005. Assembly will start in mid July and tests at firms are planned in September. Transportation to Gran Sasso will take place in October 2005.

### Control system

The control system for magnet operation is structured into three levels. A front end system embedded in the power supply and directly connected to the controller of the PS, a slow control system driving the PS through a communication protocol based on CANBUS and, finally, the interface to the general OPERA slow control. The first two layers have been defined in collaboration with the supplier and implementation is foreseen before delivery in Gran Sasso. The definition of the third layer is in progress and its implementation will be carried out during commissioning.



### Infrastructure

The schedule for commissioning depends critically on the availability of the infrastructures under the responsibility of LNGS. They include the cooling system, the availability of the UPS allocated for OPERA and the corresponding power lines. We expect the UPS and power lines to be available by summer 2005. The cooling system has been finalised by LNGS in collaboration with OPERA (LNF) in January 2005. It is designed for operation both in standalone mode (heat exchangers are operated through a chiller) or in connection with the general water cooling system of LNGS (not in operation since the Borexino accident). The water cooling system is modular and serves the heat exchangers of the magnet coils, the coolers of the PS and the RPC racks. Final drawings have been completed in January 2005 and the tender is in progress.

### Magnetization

The OPERA subsystems that are needed for the magnetization and commissioning of the spectrometers will be fully operational by October 2005. The start of commissioning depends mainly on the installation of the water-cooling system. Although LNGS hasn't provided a schedule yet, it is likely that the system will be available by the end of the year. Therefore, we plan to perform first magnetization beginning of 2006.



Fig.1: The OPERA magnets and support structures in May 2005. The support for the back arch is visible in the lower right corner.



## 1-b: RPCs

The RPC system in OPERA consists of the 22 detection layers which instrument each of the two Spectrometers. Each layer is read-out for a total of 560 digital channels, with a pitch of 2.6 cm in the bending coordinate and 3.5 cm in the other one. A big achievement was reached last March with the end of the installation of the 924 chambers, each of 3 m<sup>2</sup> of sensible region (see RPC-figure 1).



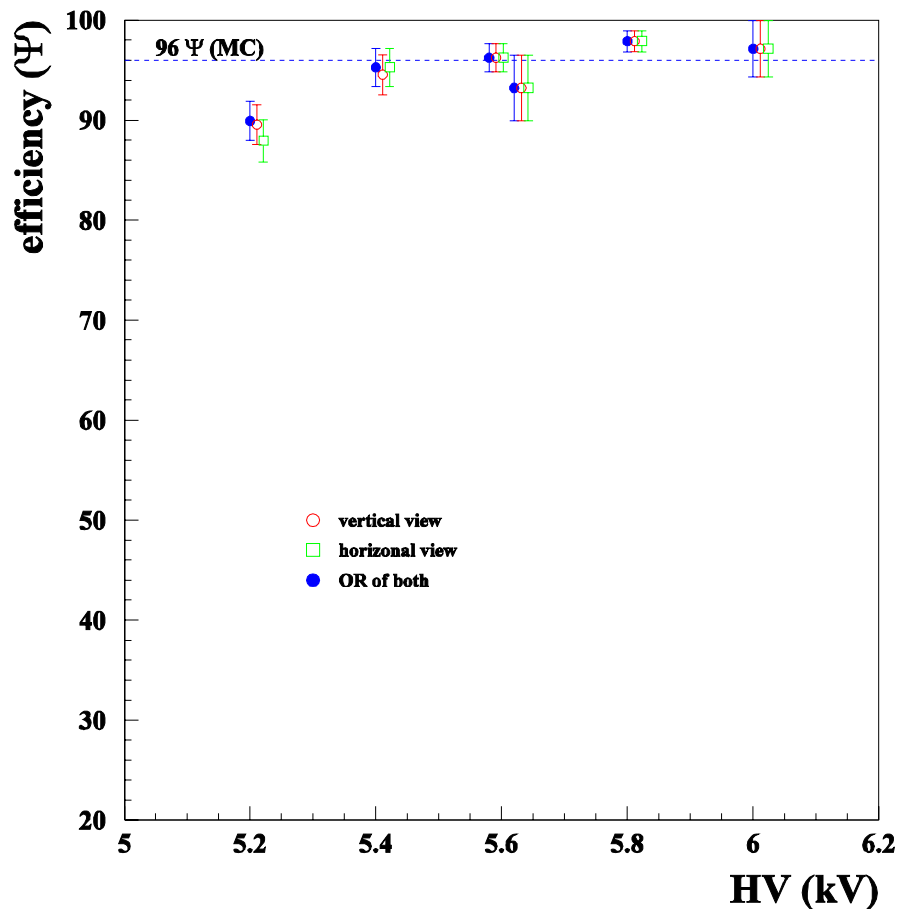
RPC-figure 1. End of the RPC installation on May 19<sup>th</sup>. The two magnets are visible from behind, each containing 22 layers of RPC chambers (each layer is fulfilled with 21 chambers). The CNGS beam is expected to come from the end of the HALL C (as in the picture).

Each detector underwent a strong series of laboratory tests before being considered for installation, for mechanical and electrical stresses and efficiency point of views. A total of 30% of tested detectors were put apart due essentially to high dark current performances. The selected ones own a reasonable expectation to well behave for all the OPERA data taking duration (10 years). During installation only a handful were replaced due to mechanical failures.



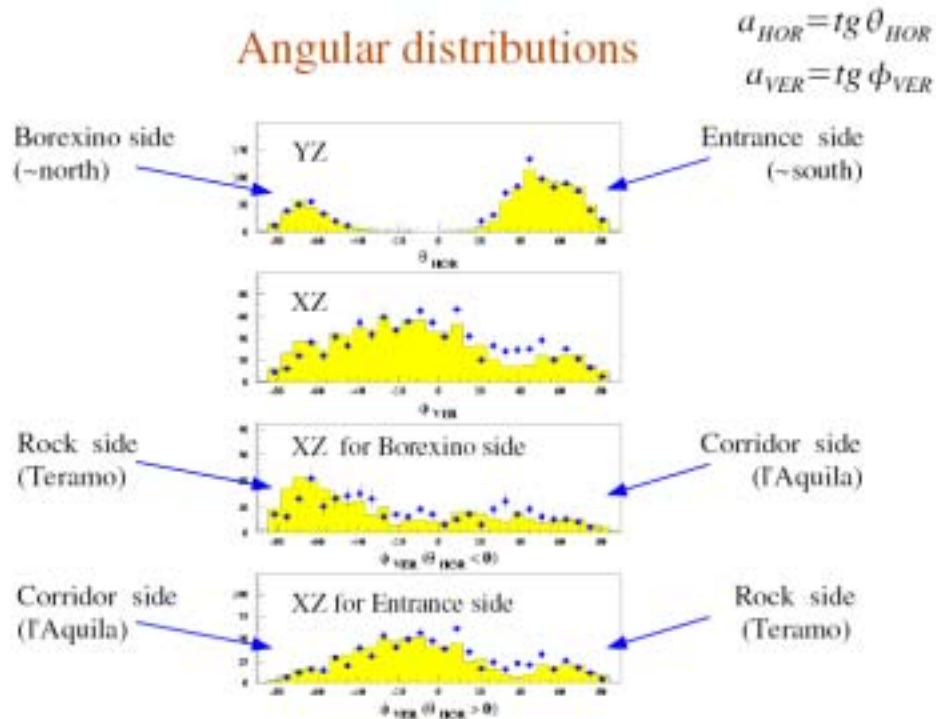
Last May we succeeded to perform a measurement on the performances of 4 instrumented layers. The data taking last 2.5 days and the results were exceptionally good since:

- 1) the 4x21 detectors showed to be fully operational
- 2) the signal read-out was clearly recorded as expected
- 3) the efficiency over the full area corresponded to the laboratory behaviour (around 96% of the geometrical area, see RPC-figure 2)
- 4) comparison with detailed Monte Carlo from previous experiments which parametrized the cosmic flux in the underground area of Gran Sasso, showed an excellent agreement in term of total rate and angular distributions (see RPC-figure3).



RPC-figure 2. The efficiency of the 4 read-out layers for different HV working points. The three data sets correspond to vertical (red), horizontal (green) and both vertical and horizontal (blue) strips read-out. The dashed line corresponds to the Monte Carlo expectation from a simulation of the RPC signal read-out developed in laboratory tests. The working point of 5.6 KV corresponds to maximum efficiency and it corresponds to the same value used in the outside laboratory building.





RPC-figure 3: The angular distributions of the collected single track cosmic muons in 2.5 days of data taking. Z is the CNGS beam axis, Y the vertical axis and X the third component of the orthogonal system (positive X towards the corridor of HALL C). The blue dots are the measurements and the yellow histogram the Monte Carlo expectation from a MACRO parametrization of the cosmic flux in HALL B. Note that no relative normalization was applied, as well as no pre-alignment of the strips. The measured total rate is  $15.6 \pm 0.5 \mu/\text{hour}$ , to be compared with the expected Monte Carlo value  $15.2 \pm 0.3 \mu/\text{hour}$ .

Parallel works were developed and tested with concern to:

- 1) DAQ data taking, in the framework of the full OPERA system
- 2) Online monitoring system
- 3) Software reconstruction of single and multiple track events for either cosmics and CNGS beam fluxes

Next steps in the project foresee the commissioning of

- 1) gas system distribution (to this respect it is still under negotiation with the management of the Laboratory the exhaust choice)
- 2) Front-End cards, each of 64 channels
- 3) Operations with the magnets on

The schedule of the latter items are compatible with the foreseen start of the CNGS beam operations in June 2006. In particular the switch on of the full system ( 2 magnets ) is scheduled for January 2006.

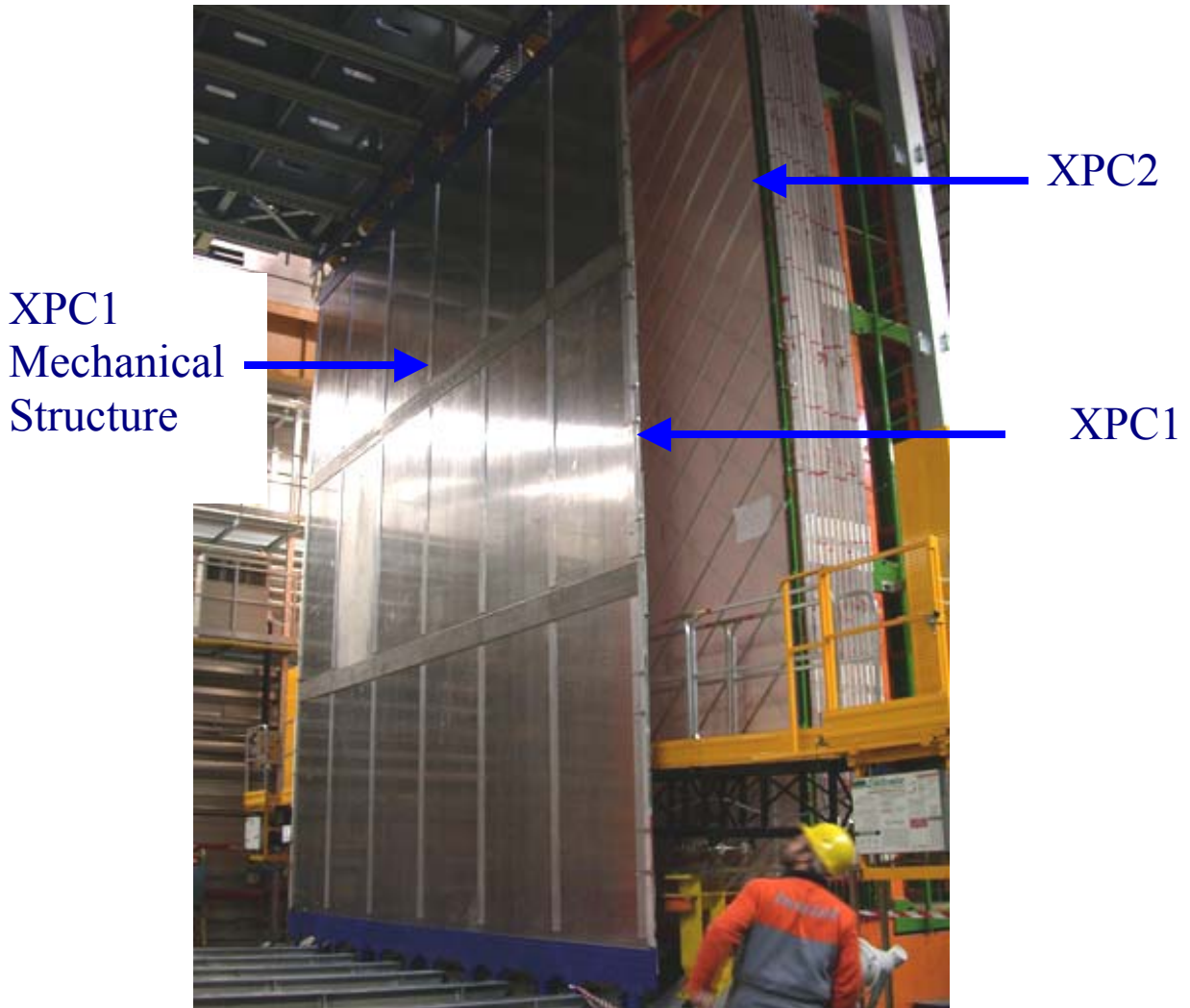


**1-c: XPC and Veto**

The XPC system consists of 2 vertical planes for each supermodule (4 planes in total). The planes are equipped with bakelite RPC and they have about the same dimensions of the spectrometer planes. The main difference with respect the RPC planes of the spectrometers is the use of diagonal readout strips to solve the ambiguity in the reconstruction of multitracks events. The XPC1 is hooked to the main structure, while the XPC 2 is fixed to the first iron slab of the spectrometer.

The two XPC planes of the first supermodule have been already mounted. All the RPC have been fully tested in the external laboratory, while after the mounting have been tested the gas flushing, the high voltage biasing and the electrical connections of the read-out system. The final gas system and the FE electronics will be implemented together the RPC system of the first spectrometer.

For what concern the XPC system of supermodule 2, all the material (RPCs, strips, mechanical structure etc.) is ready to be mounted.





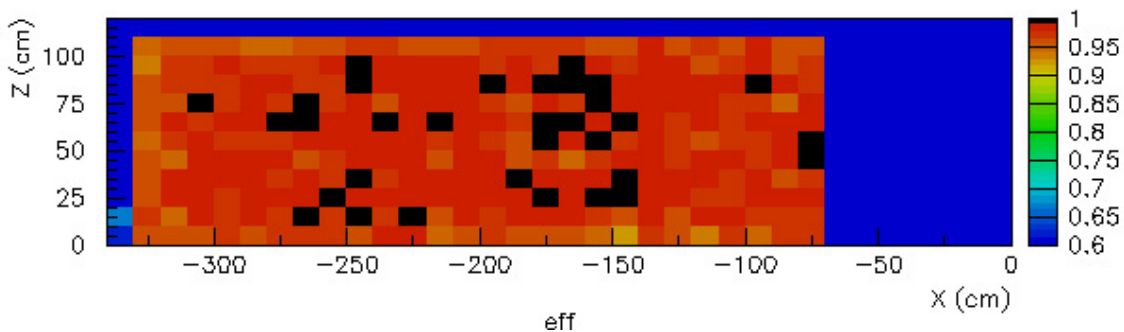
CNGS neutrinos will interact with rocks and concrete around the OPERA detector; part of secondaries issued from these interactions will enter the detector, and may induce false triggers leading a large amount of erroneous bricks extraction and subsequent scanning. The VETO is located in front of the OPERA apparatus with respect to the neutrino beam direction. It consists of two 960x920 cm<sup>2</sup> planes of glass RPC (64 glass RPC in total).

The mechanical structure has been commissioned and it is ready to be mounted in the Hall C, as well as the strip readout system.

The glass RPC foreseen for the VETO system have been designed to maximize the geometrical efficiency. For this purpose new gas inlets, frames and spacers have been realized. several real scale (240x110 cm<sup>2</sup>) prototypes have been realized and successfully tested. In October a pre-production of 10 glass RPC will be realized, while all the 100 glass RPC (64+36 spare) will be realized for the end of 2005 and mounted in the first months of 2006. A system to monitor the water vapor pollution in the gas mixture (the sensitivity is about 20 ppm) has also been realized.



Prototype of a glass RPC  
For the Veto system



Preliminary efficiency map of a glass RPC



## 1-d: HPTs

### Status – mass production

Till end of June 46 long modules for installation outside the magnet are produced and wired. 43 modules of them are successfully tested. The wire tension, the dark current and the leakage rate is in an acceptable range. 32 of the produced modules are already installed in the OPERA detector as planes HPT 1 and HPT 2.

The production of short modules for installation inside the magnet (HPT 3 and HPT 4) has been started. All parts for this production are available. During the production of short modules the rest of the long tubes for HPT 5 and HPT 6 will be ordered. All the HV boards for SM 1 and SM 2 are available and will be assembled.

The new pre-amplifier board has excellent detection characteristics but cross talk is still too high, therefore a new redesign is under test.

The first test of the TDC board (Rostock) together with the Mezzanine (Lyon) was done without bigger problems. Some changes on the designs for a stable operation are still necessary.

The slow control for the PT is under development. A new industrial standard system of the company Beckhoff will be used. It is possible to build the whole slow control for SM 1 and SM 2.

The design of the gas system is ready for SM 1 and SM 2. The system for SM 1 is being built. Construction of the gas system of SM 2 will be done in the next funding period.

### Experience from installation

Within two days in June all modules of HPT 1 and HPT 2 have been completely installed. HPT 2 was aligned better than  $500\mu\text{m}$  (within the requirement).

The HV cabling was done for both the planes. Test results show that HPT 1 is working without any problems. Low voltage was successfully tested on two modules. During the installation we got experience concerning the needed time. For one plane we need one to two days for the mechanical installation if the access to the small crane is guaranteed. Under the assumption that the movable bridge is available, the alignment needs one day and the cabling needs one to two days. After this time the planes are ready for commissioning. The installation could be done over the week end to minimize the interference with other groups.

### Trigger proposal for the PT

The trigger for the PT should be build as described in the following. To be sensitive on stopping muons, to get their track coordinates and to be sensitive on cosmics for calibrating the system, we decided to have three similar trigger stations for one SM. A





trigger will be activated if two of three XPC or RPC planes yield a signal. The trigger signal will be formed by a 2-of-3 majority coincidence to keep the trigger rate low and the efficiency high. By an additional time of flight measurement the direction of the particles can be determined.

## Funding

The construction of the SM 1 is completely funded by ~0.6M€ investment money in total. All the HV, preamplifier and TDC boards are completely funded for SM 1 and SM 2. For the gas system we will mainly use parts of the HERA-B gas system, which need some modification. The additional part of the gas system and the modifications of the HERA-B parts are funded for SM 1.

For SM 2 tubes, aluminium sheets, wire and the rest of the gas system parts including modifications are needed. We have been invited to submit a request on advanced funding in an order of ~100k€ for HPT 1 and HPT 2 for SM 2 to continue the production till end of this funding period end of June 2006. The material for HPT 3 – HPT 6 should be funded in the next period starting July 2006. We will ask for investment money in the order of ~300k€ plus operation and personal costs.

## Installation schedule for SM 1

As our first successful installations proved the mechanical installation can be organized in such a way that the interference with other groups in Gran Sasso is minimal. For commissioning we only need access from the top for planes outside the magnet while for planes inside the magnet we only need access from the side.

	production	installation	commissioning (HV + LV test)
HPT 1+2	done	done	after bridge install. and gas system
HPT 3 (short tubes)	June 27 – July 1 July = Vacation time !!! Aug. 1 – Sept. 30	Oct. 21-25	after installation
HPT 4 (short tubes)	Oct. 1 – Nov. 30	Dec. 9-13 (or 1 week later)	after installation
HPT 5	14 mod. available → rest: Dec. 5-16 →	Oct. 21-25 (if bridge) mid. of Jan. '06 or with HPT 6	after installation
HPT 6	Dec. 19 – Feb. 28/06	mid. of March '06	after installation



## Estimated installation schedule for SM 2

	production	installation	commissioning (HV + LV test)
HPT 1+2	March – June '06	end of June '06	after installation
HPT 3 (short tubes)	Aug. – Sept.	Oct. '06	after installation
HPT 4 (short tubes)	Oct. – Nov.	Dec. '06	after installation
HPT 5	Dec. '06 – Jan. '07	Feb. '07	after installation
HPT 6	Feb. '07 – March '07	March '07	after installation



2) Target Installation





## 2-a: Positioning and Alignment

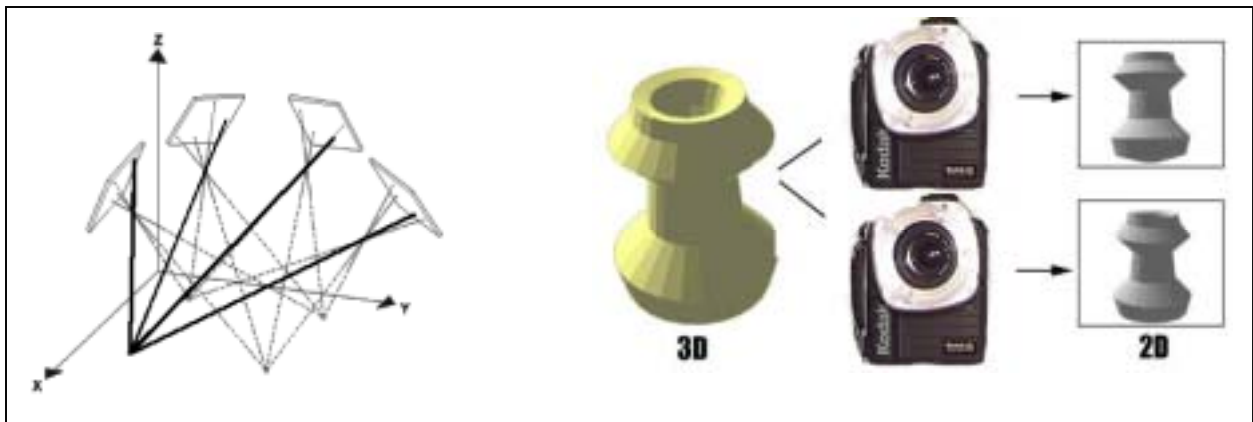
At the end of 2003 the OPERA collaboration decided to start a coherent and structured project for the alignment of the detector. This aspect is particularly important for the target, which is highly fragmented (bricks, modules of scintillator strips). The relative alignment of these components is important in order not to worsen the brick finding performance. The goal is to achieve better than 1 mm relative accuracy in the knowledge of the position of the bricks with respect to the scintillator strips. This level of accuracy has to be achieved on target elements (brick walls and target tracker biplanes), which have typically a front surface of about 50 m<sup>2</sup>.

In addition to the relative alignment to of the target components, the alignment project covers also the positioning of all the sub-detectors (the target, the HPT precision tracker, the RPC strips and the brick manipulator) in a global reference frame of the experiment, extended to the two super-modules.

The first technique, which was selected for the survey of the detector elements during and after the installation, was the “Close range targeted digital photogrammetry”. This technique is commonly used at CERN for the metrology of LHC experiments. It has several advantages: **a)** it allows to measure many points (typically a few hundreds) simultaneously; **b)** each point is measured in 3D with an accuracy better than 0.1 mm and a high level of redundancy (about 24 measurements/point); **c)** the measurement does not perturb the object which is measured; **d)** the measurements are also possible within a short distance (typically around 3m), which is the case for an underground installation. The technique is based on equipping the detector with various kinds of retro-reflective targets (working up to an angle of about 50 degrees). Some targets are equipped with precision pins which can be hosted in appropriate holes on the detector whose position is relevant for the reconstruction of the geometry, other targets are coded in order to be recognizable by the reconstruction software, other targets are fixed at the extremes of calibration scale bars in carbon fibres. Once the targets are installed, a set of pictures is taken with a high-resolution digital camera from many positions uniformly distributed on the front face of the detector. Automatic software allows for the reconstruction of the 3D image of the cloud of points measured on the detector by combining all the pictures on the basis of the information of the coded targets. The 3D position of each point is determined with a global fit exploiting the triangulations from several pictures. At the same time the analysis procedure determines the position and the orientation of the cameras (treated as rigid bodies with 6 degrees of freedom) in all the pictures.

The implementation of this technique for the OPERA survey needs is challenging, due to the cross dimensions of the detector elements (7x7 m<sup>2</sup>) and the short space available in front of them. Furthermore in Gran Sasso there was not a technical team able to support these operations.





During the summer 2004 it was organized a technology transfer from the CERN survey group of C.Lasseur in order to: **a)** perform a design study of the application of this technique for OPERA; **b)** perform a first test on a real size TT biplane in Strasbourg; **c)** start the formation of operators in Gran Sasso who could take the pictures; **d)** monitor a first application of this technique in Gran Sasso. The basic equipment (camera + a set of targets and calibration bars + reconstruction software) was bought by the LNGS for 50 Keur from the company AICON, with the idea that this kind of instrumentation and knowledge developed for the OPERA application could have been afterwards of general use for other experiments. The equipment for the photogrammetry and the local LNGS personnel were operative at the beginning of September 2004.

Since September 2004 till December 2004 a variety of measurement techniques, mechanical adaptations, new kinds of targets and analysis techniques were developed by OPERA in order to finalize and improve the survey for the walls and the TT biplanes under various conditions and locations: in the target area, on the assembly arch, from the sides etc. The final procedure for the TT and the wall implies different kinds of targets but a similar measurement time of about 30 minutes in order to take up to 200 pictures. Targets corresponding to fixed reference points on the magnet were allowing to refer each set of measurements to the global reference system. The total time for equipping the TT or the wall with the targets, taking the pictures and dismounting was about 4 hours.

Photogrammetry has been intensively used in the period going from September 2004 up to May 2005 for the debugging of the non-planarity and mechanical problems of the target elements. It allowed to measure the precisely and in great details the 3D shape of each element and to provide a direct feedback during the mechanical tests aimed at improving the deformations and alignment problems of the target elements.

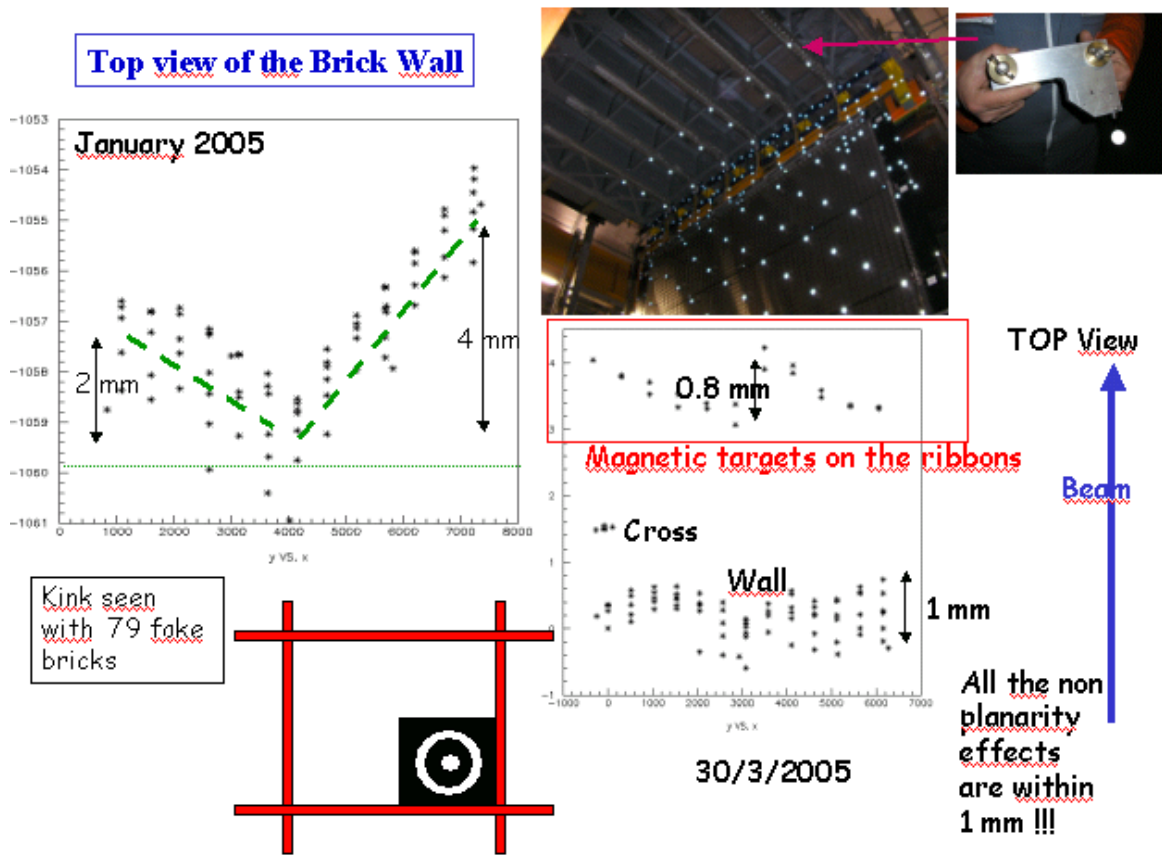
During this phase the problems related to the non-perpendicularity of the two independent semi-walls with respect to the beam axis were understood and correlated to the interference due to the pressure of the target tracker modules on the wall. The final planarity of the brick wall is better than 1 mm. During these investigations, a combined measurement of a wall and the supporting rails geometry was performed by using some spherical targets fixed on the rails.



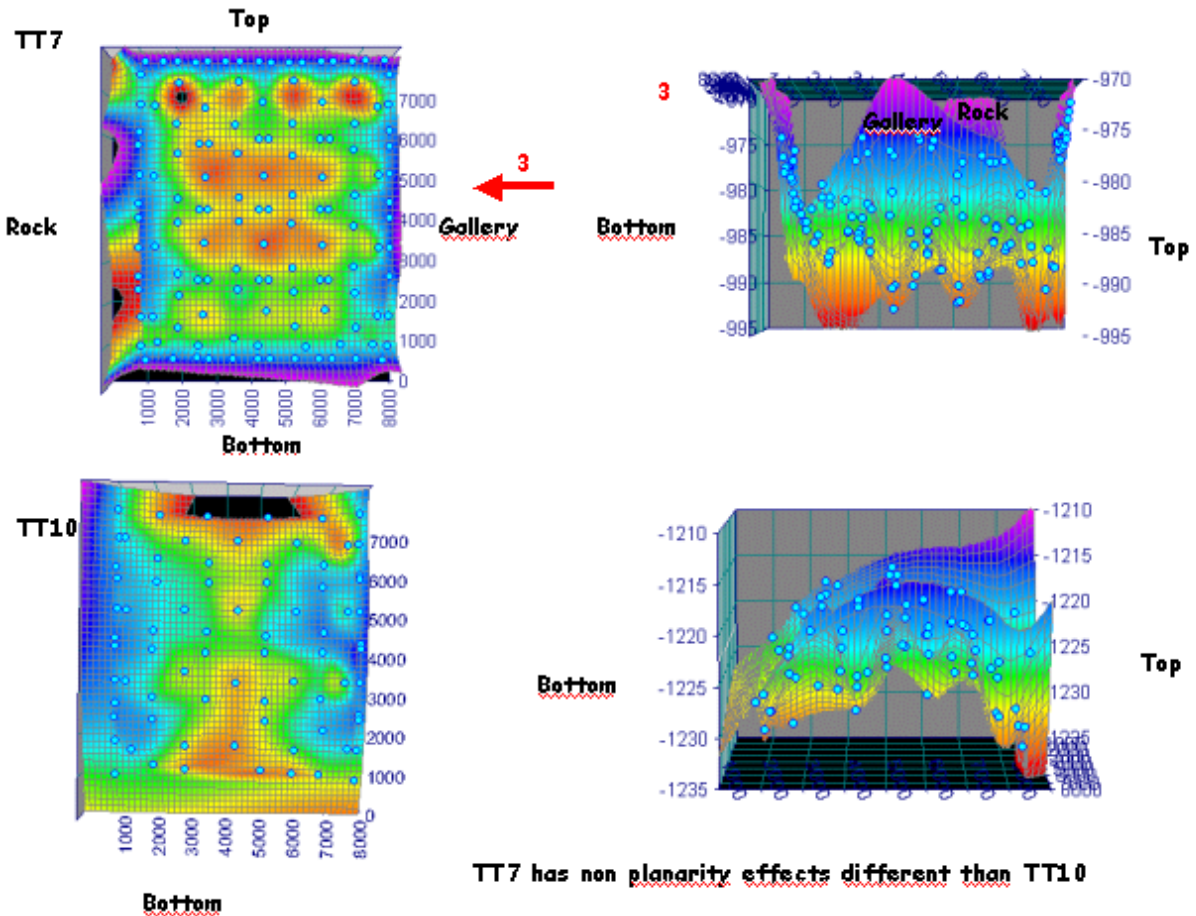
Photogrammetric Measurement 09-11.00 2004



**Fig. 2:** Example of applications of Photogrammetry to a target tracker biplane (Left) and a brick wall (Right). A fake-brick target used for the wall measurement is shown at the center

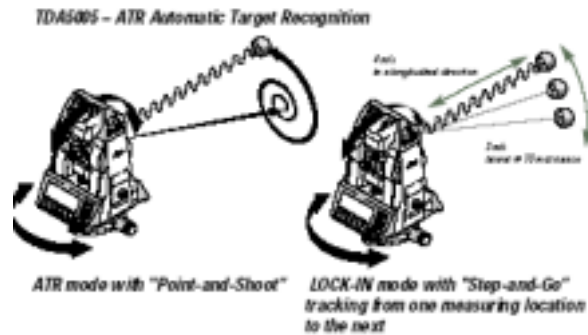


**Fig.4:** Top views of the cloud of points measured on a wall before (Left) and after (Right) having fixed the alignment interference with the TT. The final dispersion along the beam axis of the points on a wall is better than 1 mm.



**Fig.5:** 3D representation of clouds of points measured with Photogrammetry on the surface of two target tracker modules

The good accuracy of the survey tools was often contrasting with the fact that large misalignments were introduced in the first positioning of the detector elements. In February 2005 it was therefore felt the need of a complementary tool to be used in order to improve on real time the accuracy and the speed of the insertion of the TT and the walls in the target. For this purpose, a “Total Station System” TDA5005 was chosen. The equipment was financed still by the LNGS for 50 Keur from LEICA. This instrument is capable of performing 3D measurements of a retro-reflective target (CCR) with an accuracy of about 0.2 mm on the typical distances of the OPERA installation (up to 15 m). The instrument is completely automatic, remote controllable and it is able to perform the target recognition (ATR), which replaces completely the human intervention in standard teodolites to align the target by looking through the optics of the instrument. Once the target is locked in, the TDA is able to aim at it automatically even if the target is moving (tracking) with a speed up to 3-4 m/s. This feature is particularly useful during the iterative adjustment of mechanical pieces. A single measurement lasts about 15 s.



The use of the TDA has allowed improving significantly the alignment accuracy during the mounting of the target by providing a fast and precise feedback. The CCR target was easily adaptable to the already existing mechanics developed for the photogrammetry targets. The installation of the OPERA target was resumed at half May after the delivery of the new rails with pitch increased by 10 mm. The accuracy and operational speed of the TDA is such as that its was decided to take profit of that by modifying the survey procedures in order to speed-up the installation to recover part of the delay on the schedule due to the change of the rails. Indeed the TDA can be used at the same time for the operations related to the installation (alignment) and, once these are completed, for the survey of minimal sets of reference points (40 for the target tracker, which is composed of 8 independent modules and 18 for the wall which is made of two independent semi walls). This operation can be performed in about one hour compared to the four hours needed for a complete measurement with the photogrammetry. We decided therefore to unify part of the survey procedures with the alignment during the insertion.

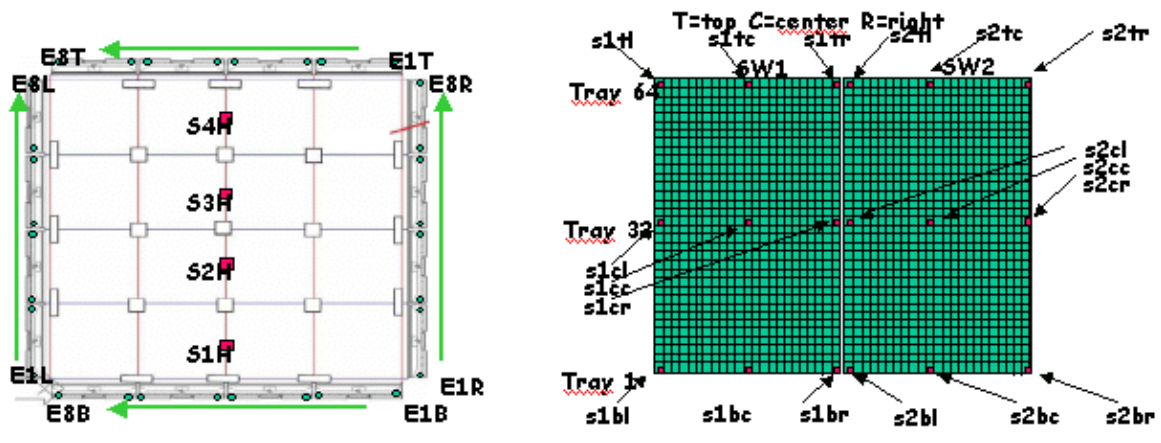


Fig.7: Reference points on the TT modules (Left) and the semi-walls (Right)





This decision implies a partial loss of some of the advantages of photogrammetry as a more accurate monitoring performed on more points and with better resolution. Photogrammetry will not be performed systematically on all the detector elements but kept for particular cases. At the end of construction of the target, some information related to the transverse structure of the target elements will not be accessible anymore and will rely on the measurements taken with the TDA during mounting. It is foreseen to use again photogrammetry by performing a global survey of the target structure from the sides. This will allow improving the relative alignment of all the components, complementing the information on the transverse structure.

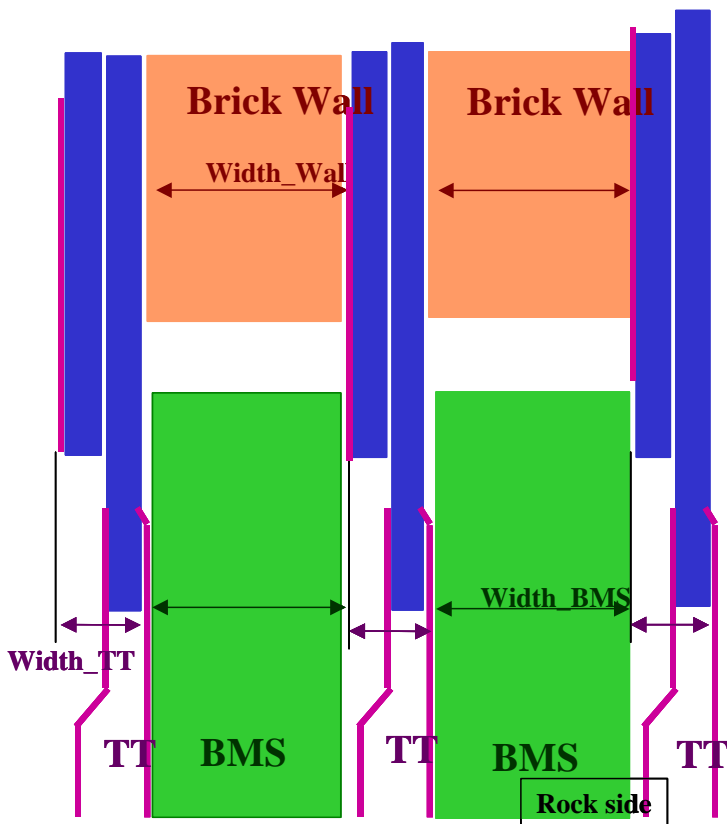
The TDA was used successfully in June also for the survey of the first HPT (precision tracker) modules inserted in the first super module. The Alignment project foresees for the next months: **a)** the follow up of the target mounting with the reconstruction of the geometry information for the database; **b)** the survey from the sides of the target to be performed before and after loading; **c)** the strengthening of the network of reference point in the Hall C with the installation of some reference pits on the floor in order to improve the connection between the two super modules and make easier the operations of alignment of the instruments in the global OPERA reference frame; **d)** the completion of the alignment of the HPTs; **e)** the installation of a network of optical fibres to monitor the displacements of the main structures of the experiment during loading; **f)** the calibration of the BMS robot movements in the global reference frame.

In conclusion: both the implementations of photogrammetry and the TDA were successful and these instruments very useful to understand the geometry of the target during the period of tests and debugging going from September 2004 to May 2005. A variety of techniques was developed during this period to satisfy various needs. OPERA is today disposing of the state of the art equipments for the alignment and survey needs.



2-b: Pitch change for the target

**Specs :**      **38.4 mm (TT) + 85.6 mm (wall) = 124 mm**



↓

thickness	clearance	
↓	↓	
• wall : 86	+ 2	= 88
• BMS : 84.5	+ 3.5	= 88
• TT : 42	+ 4	= 46
→ new pitch : 134 mm		

↓

**New target supporting rails**

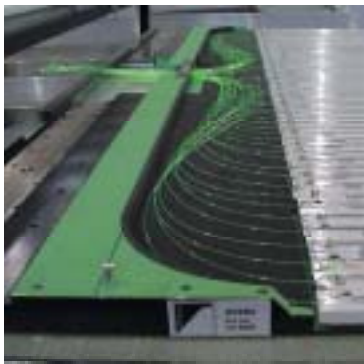
- ordered feb 05
- installation and alignment end of april
- resuming target installation half may



## 2-c: Target Tracker

### Module production

Up to now, 360 modules over 496 have already been produced tested and calibrated. The production goes smoothly without major problems. The end-caps delivery follows the module production rate. The assembly quality is still improving mainly concerning the light tightness. Some module storage problems are now more or less solved. We expect to finish this production by November 2005.



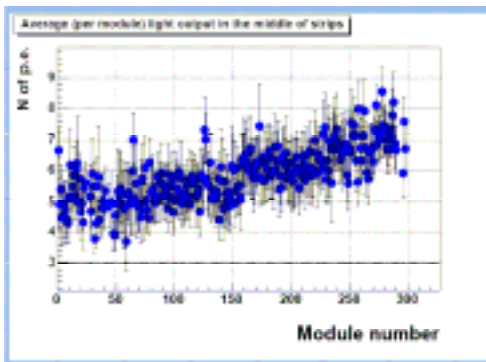
*End-caps protecting the WLS fibers and housing the PMT's and*



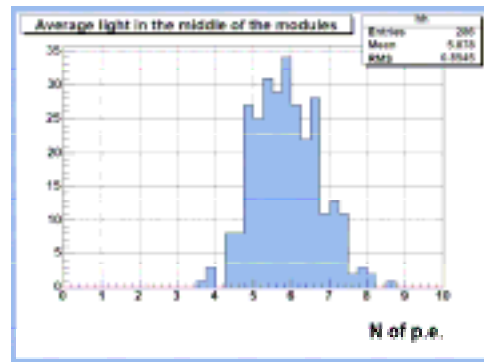
*Storage of produced and calibrated modules (ready to be sent to LNGS).*

### Scintillator strips

The delivery of the scintillator strips by AMCRYS-H company is still under way. About 26000 strips over 33000 are already delivered. The scintillator quality is improved. From 5 photoelectrons at the middle of the strips at the beginning of the production, we are observing now more than 6.



*Mean number of photoelectrons at the middle of the strips versus the module number (i.e. versus the time).*

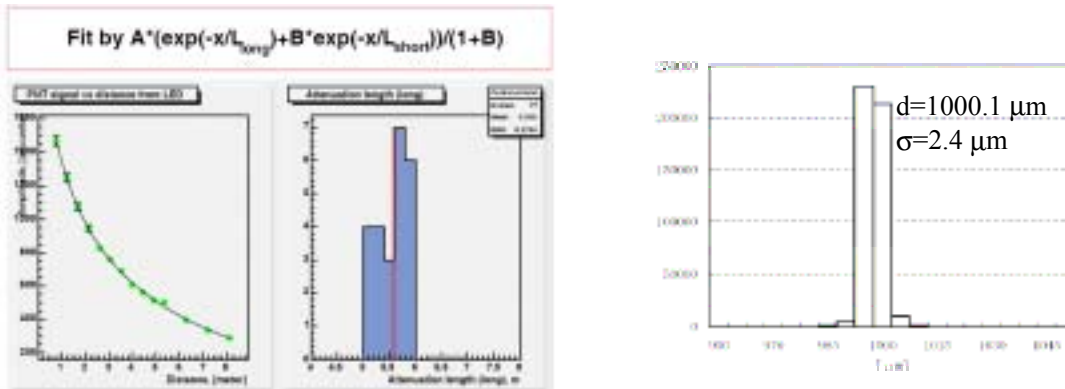


*Mean number of photoelectrons at the middle of the strips for each module.*



**WLS fibers**

The whole length of WLS fibers (310 km) has been delivered by KURARAY company. No problem has been noticed and the attenuation length and light yield are those of the initial specifications.

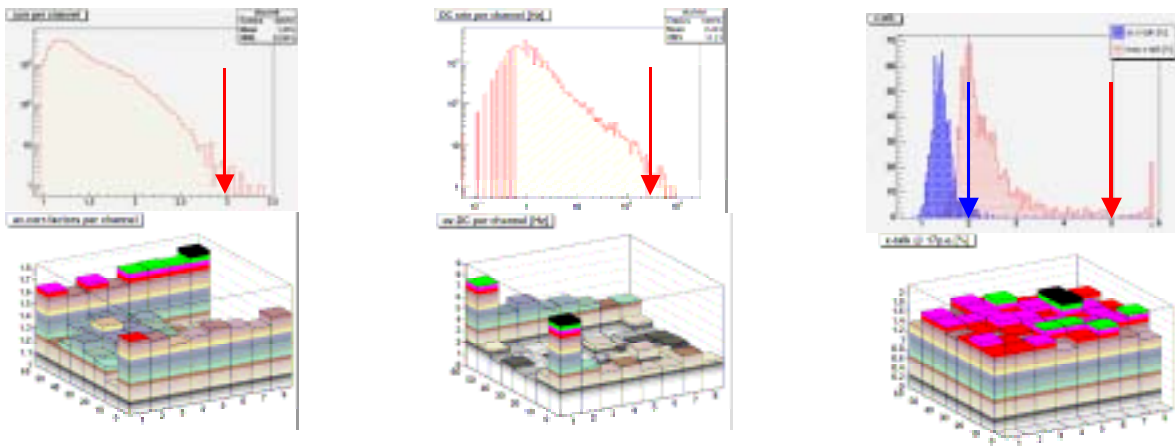


*Double exponential fit on the WLS fibers absorption distribution (on the left) and "long" attenuation length distribution (right) of a KURARAY batch (the red line indicates the mean required value).*

*Diameter distribution of on batch (40 km) of the WLS fibers.*

**Multinode PMT's**

All the PMT's (1040) are delivered by Hamamatsu company. The rejection ratio is 5.5% (same as for MINOS experiment). The main reason of rejection was an excessive cross-talk between channels. The dark count rate is lower than 2.5 Hz and better than our expectations. This last point is very important for the experiment as the trigger is given by the Target Tracker and the trigger threshold would be as low as 1/3 of photoelectron.



*PMT channel gain dispersion*

*PMT dark count*

*PMT mean cross-talk*



### Target Tracker installation in Gran Sasso

After some dimensional problems and after increasing the pitch between target walls, the Target Tracker and brick walls installation has been resumed beginning of May 2005. Up to now, 5 TT walls have successfully been installed. In order to well maintain straight and at the nominal position, the flat beam supporting the first inserted TT wall near the magnet is guided by a special mechanical system fixed on the HPT supports. Spacers on the upper side of the TT walls have been added in order to well maintain constant the distance between TT walls. This last modification has significantly improved the TT wall planarity and alignment. The TT wall insertion and alignment have also been improved and it takes now only one day instead of two initially planned.

The assembly procedure of the TT walls in Hall C has also been improved by reinforcing the platform (partially fixed on the Borexino PC wall) used for this purpose. Tests have been developed in order to monitor the TT wall planarity and indicate if all parts remain in the allocated volume.

For the moment, one TT/brick wall per week is installed with the aim to go to 6 TT/brick walls per month by the end of June.

The TT modules are tested for light leaks before and after mounting them on a TT wall using the DAQ system. Very soon, we plan to start making signal correlations between the inserted TT walls for DAQ debugging, recording cosmic muons and monitoring the radioactivity.



*First Target Tracker flat beam alignment system*



*Spacers maintaining the Target Tracker flat beams straight and at the right distance between each others*





## 2-d: Brick wall

### Mechanical properties

The brick wall is a stainless structure made by 2 identical and independent subparts called SemiWall (SW). Each SW consists of 27 stainless ribbon (cross section area:  $0.8 \times 10 \text{ mm}^2$ ) suspended from above and tensioned from the bottom by mean of a special spring-tensioning system. 64 horizontal trays are welded to the ribbon (3456 welded point/ SW) in order to obtain a both solid and light skeleton-structure to be loaded with bricks. The horizontal trays are made by 0.7mm stainless sheet metal preformed to have a “U” section shape.

The overall dimensions of SW are 3332 x 7330 x 85.6 mm and its total weight is about 200kg. A SW will contain 1728 bricks. The ratio between the dead weight and the loaded weight is near the 0.7%.

The design tolerances are very close, the most critical:

- Trays Pitch:  $105.3 \pm 0.1$  mm
- Trays Internal Width:  $82.6 \pm 0.2$  mm
- Trays Length:  $3358.2 \pm 0.25$  mm
- Total Height:  $7330 \pm 0.8$  mm

More geometric tolerances have been added, the most significant:

- Trays Parallelism: 0.2 mm
- Trays Planarity: 0.2 mm

### The mass production

The OPERA Experiment needs 62 Brick Wall (31 for each SuperModule) corresponding to a 124 SW production. To satisfy the amount of this production and to assure the reproducibility of the SW an automatic machine has been designed.

The machine is equipped with a laser-welding tool moved by an auto-positioning system of carriages. The trays and the ribbon are pre-positioned in their nominal relative position and than held together until the end of welding operations by a mechanical reference tool. Up to now have been produced 24 SW with a production rate of about 2.5 SW/week. It's foreseen a speed up by the end of June 2005 in order to reach a 3 SW/week speed production. Several corrections and an alignment of the machine have been needed to match the drawings specs. A conditioning air system has been mandatory to keep the room temperature at  $24 \pm 4^\circ\text{C}$ . The following numbers show the SW as built:

- Trays Pitch:  $105.3 \pm 0.1$  mm
- Trays Internal Width:  $82.6 \pm 0.25$  mm
- Total Height:  $7330 \pm 0.6$  mm

An acceptance test has been performed on each SW produced until now. It needed some reference gages and an optical theodolite. A random test is normally performed on the trays to check the dimensions and the geometry. To do it we use a 3D Coordinate Measuring Machine at LNF.

Also 18 special frames have been built to transport, to storage and to install brick walls at LNGS.



**The installation**

The installation operations have been studied and applied several time before the first wall insertion. The insertion is done by the side of the experiment by mean of a special sliding tool designed and built at LNF. Also a final alignment is independently performed on each SW. It takes more then 50% of the installation time and is done by using mechanical tools for fine tuning operations (by LNF), optical instruments (auto level AE-5C by NIKON) and a theodolite total station with automatic target recognition (TDA5005 by LEICA). The positioning precisions are the following:

- Vertical: < 0.3 mm
- Transversal: < 0.5 mm
- Longitudinal: < 0.5 mm

The overall planarity of a brick wall (2 SW to constitute a plane) is: < 1 mm

Up to now have been installed 6 SW with a training speed of 2SW/week. By the end of June the installation speed will be of 6SW/2weeks (i.e. 3BrickWalls/2weeks)

**The present numbers**

SW produced:	24 (20% of total production)
SW tested:	24 (100% of present production)
SW installed:	6 ( 5%)
Installation Speed:	2SW/week
Production Speed:	2.5SW/week

**The forecast**

End of SW production:	March 2006
SW to be tested:	(20% of total production)
Installation Speed:	6SW/2week
Production Speed:	3SW/week
End of SM1 installation:	October 2005 (end)
End of SM2 installation:	5 months from the starting date



**Extracting the SW from the production machine**



**Installing a SW @ LNGS**



## 4) DAQ, Network and TT commissioning

### General features

The OPERA DAQ system is based on the use of an Ethernet interface close to the front-end electronics of each sensor of the experiment. This Ethernet interface is a daughter board (called Mezzanine) including a sequencer of FPGA type (ALTERA APEX EP20K200), a FIFO (131 kwords of 32 bits wide), a micro-processor running under Linux (Multi Chip Module or MCM designed by AXIS and including a processor of the ETRAX family, memories and Ethernet transceiver). The Mezzanine board and concept have been designed, tested and validated in the IPN Lyon.

This interface is plugged on 4 different types of mother boards which are specific to the various sub-detectors of OPERA :

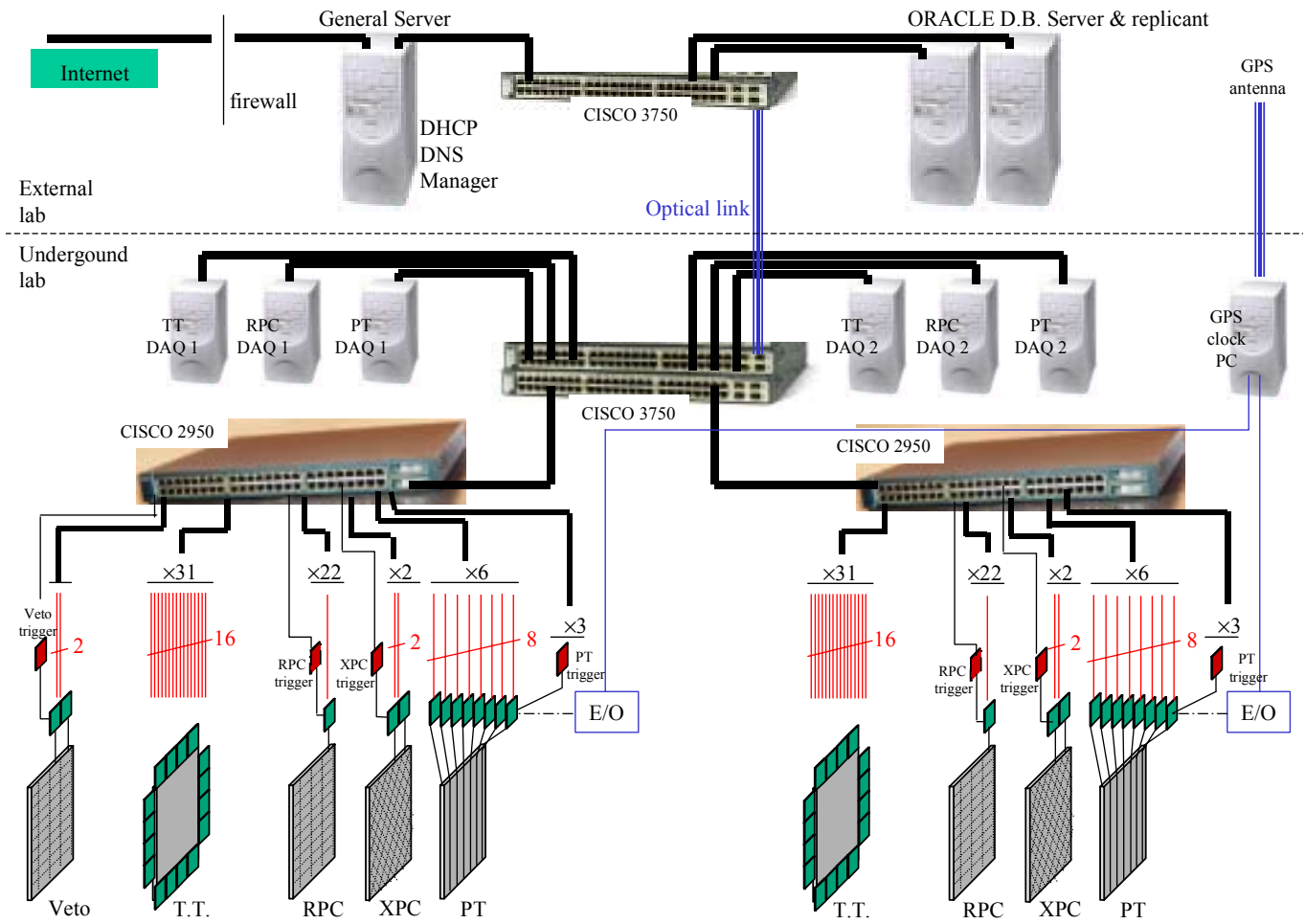
- Target Tracker. A dedicated board (called CAMEROP) has been designed, validated and produced by the IPN Lyon. This board hosts the Mezzanine, the ADC for PMT's charge readout (64 channels multiplexed), different DAC's for the F/E configuration, a high voltage module (ISEG), a LED pulser for on-line monitoring, a clock receiver system. The CAMEROP is a custom 100mm\*290mm board produced by the ELPACK company (Valence, F-26000).  
1 CAMEROP/Mezzanine system is used to readout 1 MaPMT.
- RPC/XPC/Veto. The Mezzanine is plugged on the Controller Board (C.B.) designed and tested by the Naples group. This board is in VME format (VME bus not used) and performs the readout sequencing, zero suppression, event timestamp (through the Mezzanine), clock reception.  
1 C.B./Mezzanine is used to readout 1 RPC plane.  
2 C.B./Mezzanine are used to readout XPC or Veto plane.
- Precision Tracker. The Mezzanine is plugged on the TDC board (VME standard) which includes 12 TDC chips (96 channels in total), a clock receiver and a readout sequencer.  
8 TDC board/Mezzanine are used to readout a drift tubes plane.
- Trigger boards. These boards are used to implement and distribute hardware trigger to RPC/XPC/Veto Controller boards and to the TDC boards. They will be equipped with Mezzanines for configuration, remote trigger setup and recording. There will be 6 trigger boards for the PT, 2 for RPC, 2 for XPC, 1 for Veto.

The number of electronic boards for the DAQ (not including spares) is :

- 1151 Mezzanines (T.T. + RPC/XPC/Veto + PT + trigger)
- 992 CAMEROP
- 96 TDC boards
- 54 controller boards
- 11 trigger boards



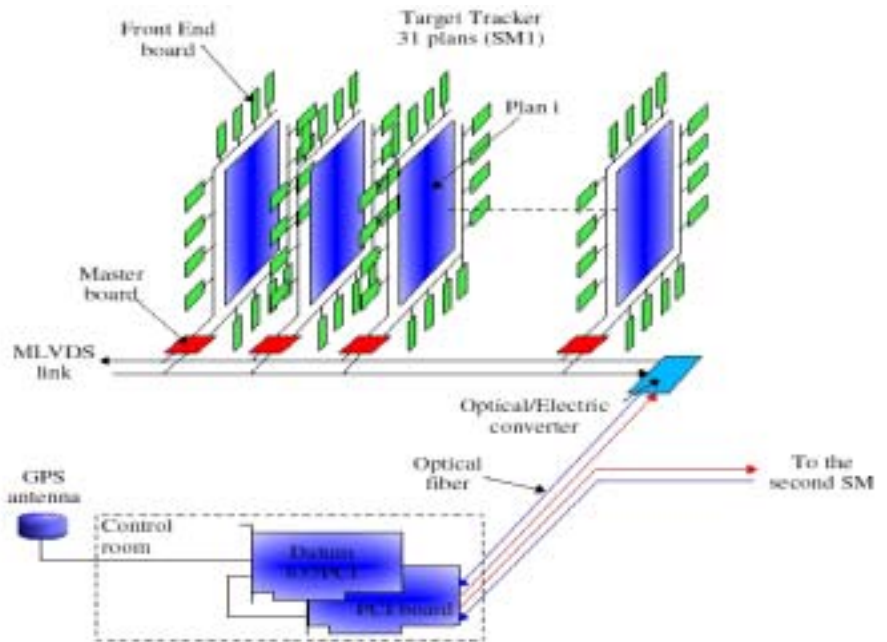
The general layout of the system is shown in the next Figure.



All the boards are equipped with a clock decoder system.

The clock (20 MHz) is distributed from a dedicated PCI board which receives and decodes the GPS signal send from the outside to the underground lab through the 8 km optical link. The clock is then converted to an electrical signal and distributed to the sensors through a cascade of M-LVDS links.

The GPS PCI board and the so-called “Master boards” have been designed, validated and produced in IPN Lyon.







### **Network and event building**

The client/server protocols from the different Mezzanines to the DAQ and Manager workstations are based on the CORBA standard and implemented in C/C++. The graphical user interface is developed in GTK and a temporary postGRES database server is used for validation before migration to ORACLE.

The general software is divided into sensor / DAQ / Manager applications with interfaces accessible through the CORBA bus. We use presently the omniORB4.0.5 release of the CORBA libraries. This system is also used for the Brick Manipulator Manager which allows simplified interface to the DAQ.

The raw data stored in the Mezzanine's FIFO are formatted and processed in the sensor applications and then send to the DAQ PC. These workstations sort the data in time, apply the filtering algorithms and the event building methods.

The network is based on CISCO products (switches of level 2 – 2950 24 or 48 ports – and level 3 – 3750 24 ports – for routing) and divided into different VLAN :

- VLAN server : 172.16.0.0
- 4 VLAN for TT data : 172.16.2.0 / 172.16.4.0 / 172.16.6.0 / 172.16.8.0
- 2 VLAN for RPC/XPC/Veto : 172.16.10.0 / 172.16.12.0
- 2 VLAN for PT : 172.16.11.0 / 172.16.13.0

All the switches have 100Mbits inputs (connections of the Mezzanine to the switches) and 1Gbits output (connections to the level 3 switches). The internal network will therefore

The connection to the outside world is performed after a firewall through the OPERA General Server which also provides the DHCP, DNS, Web services... The maximal output bandwidth is limited to 32 Mbits with the present configuration of the LNGS network.

### **Development status**

#### **a/ Electronic boards production**

The status of the boards production is the following :

- CAMEROP boards are produced (1050 including spares). They are tested both electrically and functionally in the IPN Lyon with very satisfactory results.
- RPC controller boards. 1 prototype has been tested and validated. A pre-series of 5 boards is under production.
- TDC boards. 3 prototypes have been produced. 1 is under evaluation in the IPN Lyon.
- Trigger boards. 1 prototype in under development in Naples. It will be tested before summer '05.

All the boards for the spectrometer (RPC CB, TDC boards) should be produced for the spectrometer commissioning tests foreseen by fall '05. The trigger boards will be produced later.

The boards for the clock distribution system have all been produced for SM1. The rest of the production should be completed by the end of the year.



### **b/ Mezzanine status**

The Mezzanine version 1 (using a sequencer FPGA APEX EP20K and a MCM of the 2+8 series) has been validated and produced in 200 samples. These boards are used for tests and commissioning (both of TT planes and of the DAQ). They are currently installed on the TT planes inserted in the detector. Up to now around 6000 electronic channels have been tested with the system.

The final version of the Mezzanine will nevertheless be different. We replace the sequencer by a FPGA of the so-called “cyclone” family, which is largely cheaper (around a factor 10

reduction) and we upgrade the MCM by using the MCM 4+16. This chip includes twice as much as memory capacity and also a new Ethernet transceiver that improves the network performance. The upgrade has been performed in 2 steps :

- A temporary prototype has already validated the use of the upgraded MCM chip.
- The final prototypes are under production and should be tested by the end of July '05.

In the final series we will produce 1225 boards (with a pre-series of 100 to commission the production process). Tests are performed in the IPN Lyon.

A version of firmware and high level software has been developed and tested for all the sub-detectors. The most advanced (and almost final) is the TT one. For the RPC and the PT, 2 test benches are currently used for tests and development : one in the Naples, one in the IPN Lyon. The remaining developments concern mostly the GUI and high level software applications.

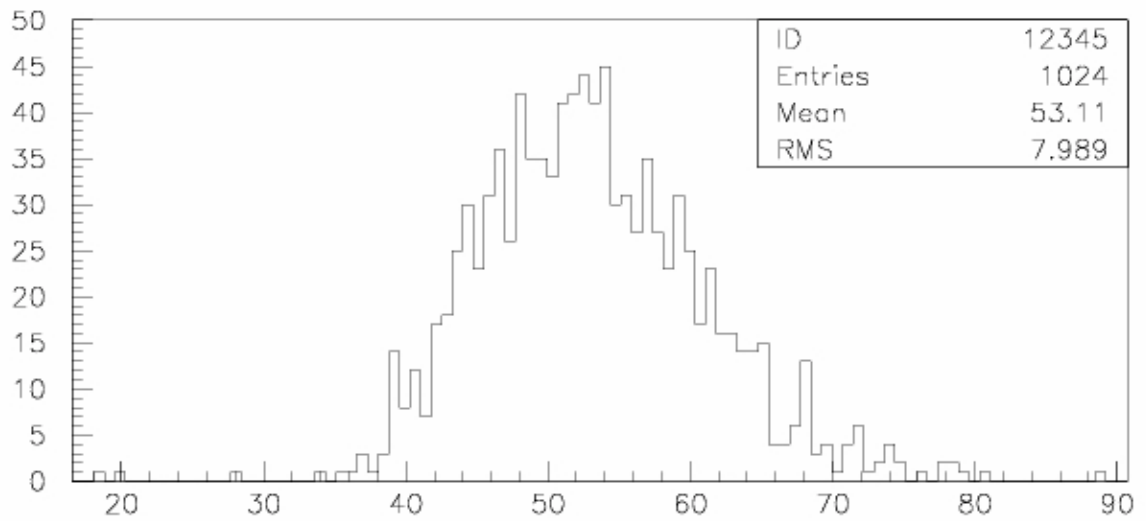
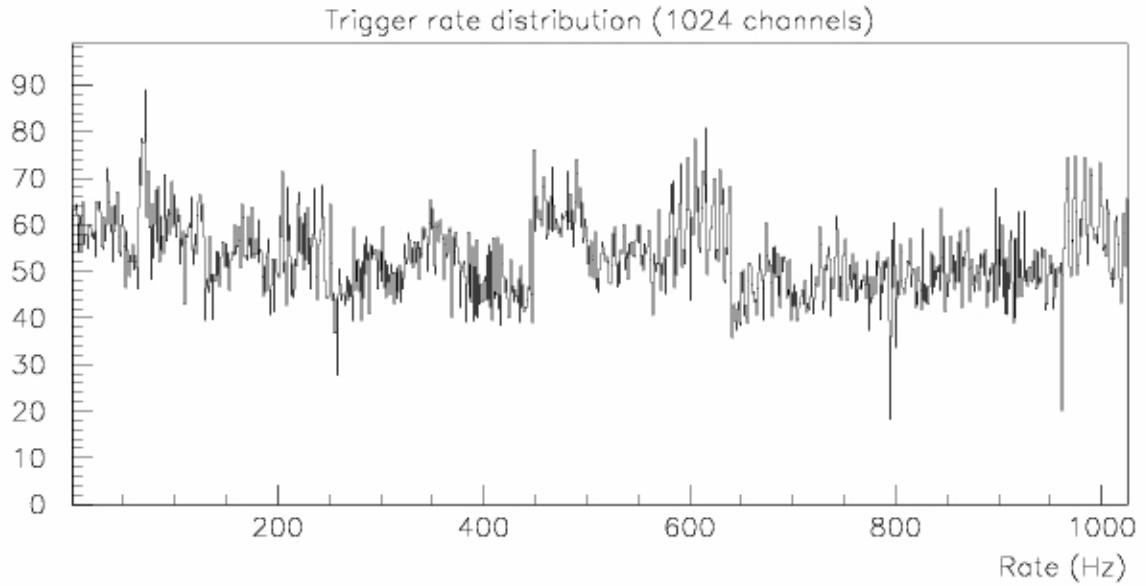
### **TT Commissioning**

The DAQ system in its final configuration (and with the present version of Mezzanines) is used since more that 1 year for the TT commissioning :

- at the production step in Strasbourg, for all the modules : measurements of scintillator response to a m.i.p. and fibre attenuation,
- in the Gran Sasso laboratory for the planes which are mounted, before insertion in the detector : search for light leaks, measurement of trigger rates, fibre response integrity, gains equalization... Typical trigger rates distribution for 1 complete TT plane (1024 channels) are displayed in next figure (results in counts per second) :

The software used for these measurements is the final version of the DAQ CORBA software. Dedicated tools have been included in the DAQ run control to perform quick and efficient measurement of trigger rates for instance.

The next critical step will be the test of the network configuration and performance. This work is already started in Gran Sasso with the TT planes inserted in the detector and with real signals. It will be completed by the summer.





## 4) Brick preparation and handling

### 4-a: Lead

By June-2005 the lead company JLGoslar at Goslar (Germany) has been awarded the lead contract for the OPERA lead project. This includes the production of all lead plates for the OPERA detector according to the OPERA specifications, the lead surface cleaning machine, the automated packing into previously specified cartridges and the transportation to the Gran Sasso Laboratory.

As of this date, semi-regular meetings have been set up to monitor the implementation of the production line and the installation of the cleaning machine. The latter is the most time critical part, as it requires the acquisition of components (ultrasonic actuators, controls units), which typically have a 3 months delivery time. The majority of technical drawings had already been completed before the contract was awarded, thereby avoiding further delays.

The time schedule requires the start of the lead plate delivery 6 months after the contract has been signed, which is now foreseen to be January 2006. The complete production line will be operational in December 2005. A one month start-up procedure is needed to ramp up the production to full capacity.

The automated packing into the lead cartridges requires communications and exchange of information with the BAM-project (including the company Tecnocut). These are presently ongoing.

The quality control is part of the lead contract. This includes among others the monitoring the lead plate thicknesses. Compliance with the specifications will be accomplished by weighing. Presently envisaged is the weighing of every batch of 56 plates (equal to one brick). This procedure has been tested last year and found to be a viable and satisfactory means to determine plate thicknesses. The lead plate punching tool has been modified and improved over the past months and enough expertise is available to ensure the required cutting quality. It is envisaged that one person from the University of Münster will be on-site during production to overview the activity.

The low radioactivity control will be accomplished by measuring the  $^{210}\text{Pb}$  beta-radioactivity of a sample taken from every batch of 40 tons of lead. Forty tons is the typical size of a batch when it arrives from the lead production company, resp. the lead quarry. Some of these samples will be measured by the German "Physikalische Technische Bundesanstalt" (PTB) in Braunschweig, Germany, which will also provide a certified document for each sample sent to them. Parallel to this, the University of Münster group is presently setting up a small (portable) facility, which also allows measuring the  $^{210}\text{Pb}$  activity level. The facility will be able to determine the activity level of at least eight plates at a time. The activity level will be calibrated against some standards as measured by the PTB. This portable facility will have to be installed into the low level environment at Gran Sasso (space requirement ca. 1 m<sup>2</sup>).

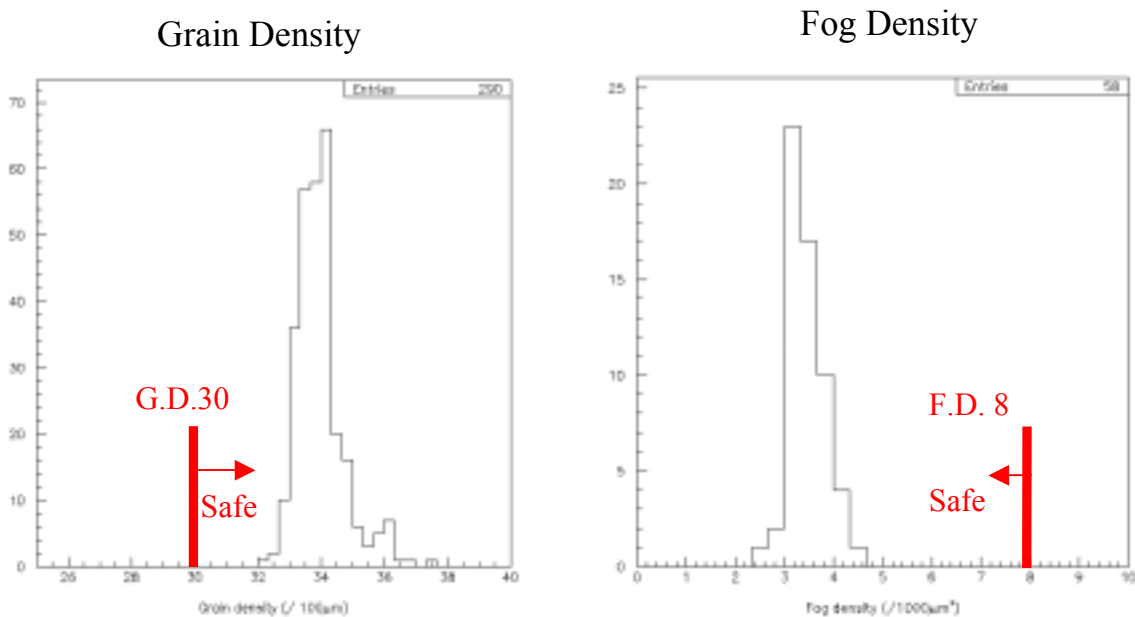


### 4-b: Film production and Refreshing

OPERA full detector requires 12 Million films (size= 10cm times 12.5cm).

Until June 18, 2005, 78% of 12M has been produced at Ashigara Factory of Fuji Photo Film Co., Ltd and transported to TONO mine where the refreshing facility of Nagoya University exists. At TONO refreshing center, 43% of 12M has been refreshed. And until today 30% of 12M have been delivered to Gran Sasso.

The film qualities (film sensitivity, fog density and so on) have been checked before refreshing and after refreshing. In the figure shown below, the measured grain density and the fog density after the refreshing were shown. We set the threshold as GD 30 and FD 8 for good quality.



The first film shipping ceremony from Japan to Italy was taken at Dec 7<sup>th</sup> 2004 with a number of attendances relating to this Job including vice-president of Nagoya University and the director of TONO geo-research center. At Jan 24, first film arriving ceremony from Japan was taken in Gran Sasso lab with the attendance of OPERA members, Director of Gran Sasso lab and vice-president of Nagoya University. Japanese and Italian new papers and TVs reported these ceremonies.





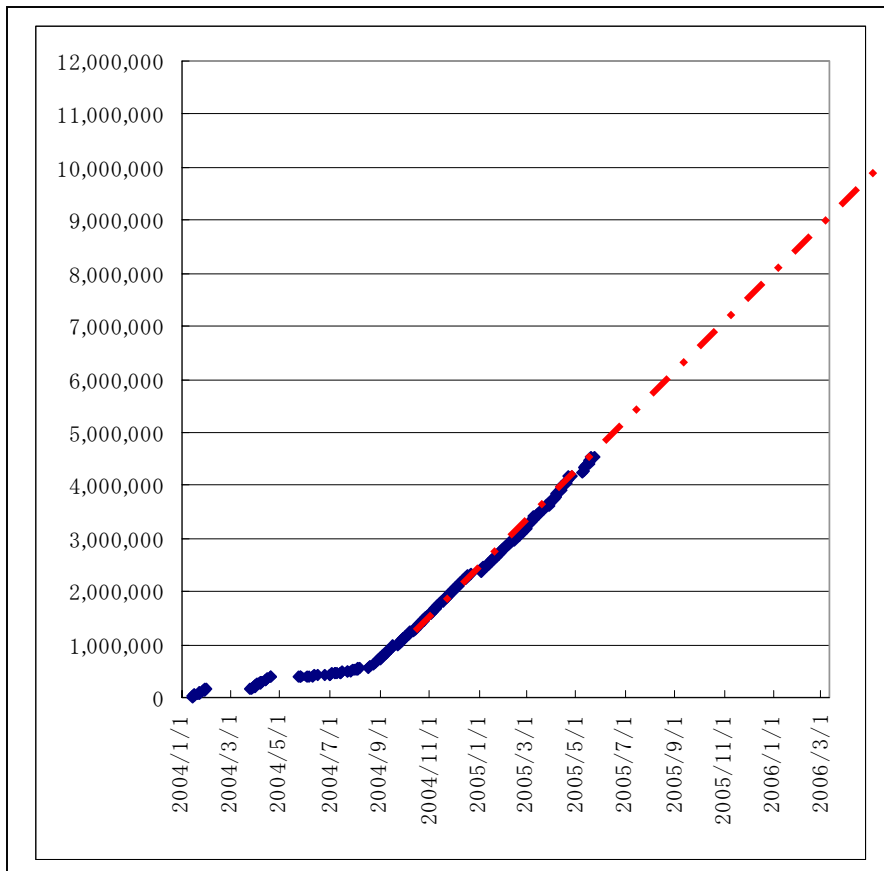
Film delivery ceremony at LNGS

From left to right :

Prof. Coccia (LNGS director),

Prof. Yamashita (Deputy president Nagoya University)

Prof. Niwa (Deputy spokesperson OPERA collaboration)



As you can estimate by the extrapolation of the production curve shown in the above figure, until spring 2006, all of the films will be refreshed in TONO mine and shipped to Gran Sasso Laboratory.

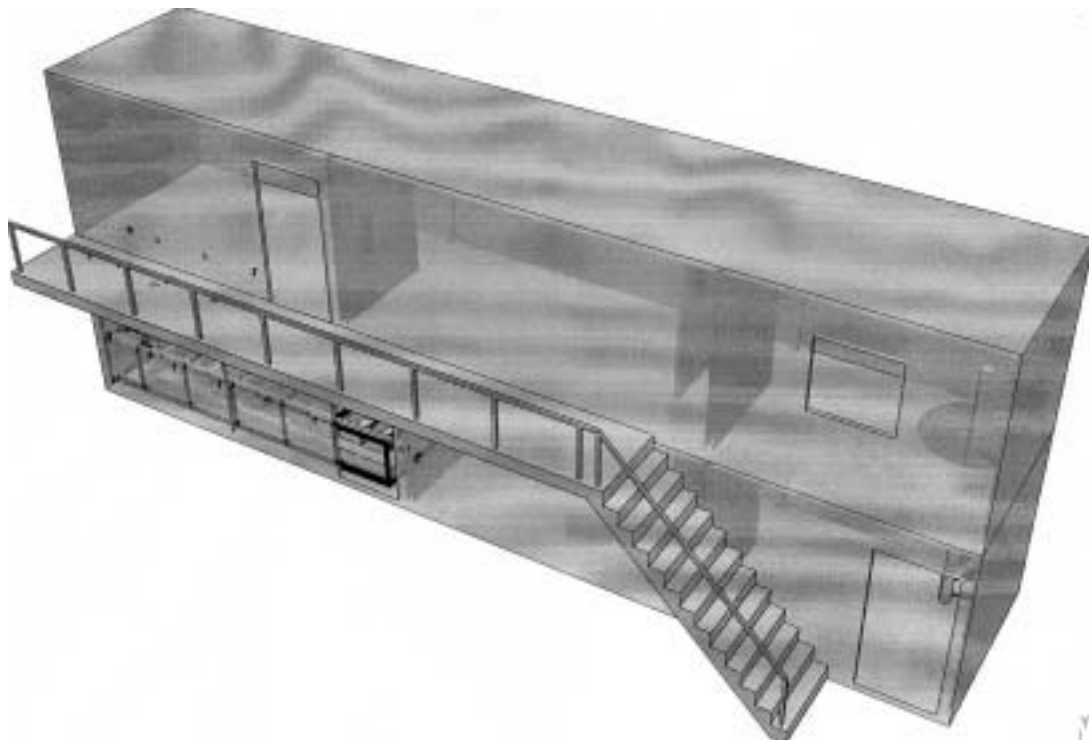


#### 4-c: Changeable sheet

There are two roles of Changeable-Sheet. One is to tag right bricks where neutrino interactions occur. And the other is to eliminate the scanning load. For both purposes, low background track density in the CS is essential.

A number of tests were carried out in order to confirm the story of Changeable sheet baseline written in the report (CERN/SPSC 2002-021). We found one severe problem that makes the baseline be changed.

In the baseline, we intended to use so-called self-refreshing features of the OPERA emulsion film. According to the baseline idea, CS films were planned to be packed in Japan with high relative humidity like 90% R.H. After the transportation to Gran Sasso, those packed films will be kept at high temperature like 30°C for several days and refreshed. But by the tests, it became clear that to pack films with high humidity is dangerous because it raise fog density rapidly when it was kept at high temperature like 35 °C. With relatively low humidity like 80%, it was safe but the refreshing rate was too low to satisfy the requirement. Therefore we decided to change the refreshing method from self-refreshing to full-refreshing at Gran Sasso underground. We have started the construction of CS refreshing facility that is just a small copy of TONO refreshing facility build in Japan. It will be ready at the middle of September in Gran Sasso. After several test productions, we will be ready to produce CS units at the end of October.





#### 4-d) BAM

The Brick Assembly Machine (BAM) is an automatic system whose aim is the mass production of about 207000 brick of the OPERA detector in about 220 working days. This will mean about 960 brick a day, meaning a production rate of about 1 brick each 30 seconds for 8 working hours a day. A brick is constituted by pile of 56 lead sheets interleaved with 57 emulsion films. The pile has to be performed within 50 micron piling precision and with no additional deformation to the lead sheets (10 micron flatness) and no distortion and chemical effects on the emulsion films while automatic handling occurs.

During 2004 the prototyping phase of BAM and brick packaging was terminated. Till June two packaging options for the pile packaging were studied: vacuum and mechanical packaging. After severe tests measurement on robustness and reproducibility of the packaging dimensions, a final choice was done towards the mechanical packaging. The final solution is based on the use of a metallic (aluminum) structure being laid around the pile. The pile is protected by a 1mm black polyethylene sheet all around in order to avoid direct contact of emulsion films with Al and to guarantee a first layer of light tightness to the films (see fig 1). Once closed with PE and Al, the pile is then wrapped with two layers of Al adhesive tape which guarantee the total light and gas tightness of the packaging (see fig 2). Tests in this direction were performed showing the absolute safety of such packaging for the emulsion films. Accelerated aging tests were also performed at 33 °c for 4 months showing no degradation of emulsion performances.



Fig. 1, Mechanical packaging



Fig. 2, Al tape wrapping

In parallel, emulsion-lead compatibility tests were performed in order to validate the choice of the lead hardener. PbCa, PbSb and PbAgAl samples were studied. No effect in mechanical packaging was detected, while PbCa showed poisoning effects in vacuum packaging. PbSb was the final choice showing no poisoning effect in any packaging and being an intermediate value of hardness with respect to other two options.



Concerning the brick production, several tenths of bricks were produced in manual and semiautomatic mode, both for test beam activity and for BAM packaging tests. In November test beam first bricks with mechanical procedure in semiautomatic mode were produced, showing a relevant level of reproducibility in terms of dimensions with a sigma at level of about 100 microns (see fig.3).

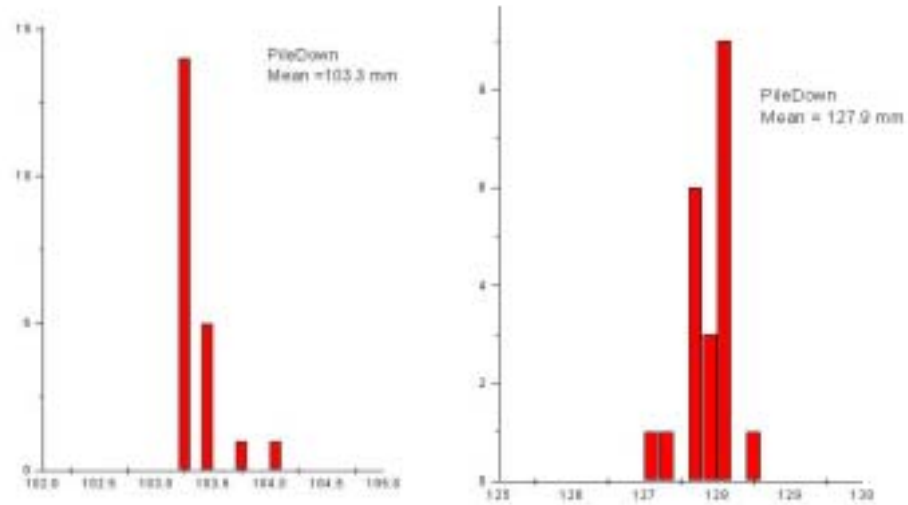


Fig.3 Reproducibility measurements of brick size

The BAM construction was started in November in firm site, starting with the assembling of first piling station using two anthropomorphic robots (see fig.4). In December a manual pressing unit was included (see fig.5).



Fig 4 First piling station under test



Fig 5 Piling station with manual pressing machine



In January 05 it was started the construction of the final set-up of the automatic piling-pressing station (see fig 6 for layout drawing). Figure 7 shows the present status of the first automatic piling pressing station. The pressing unit has been tested with real bricks validated with cosmic track tests in order to monitor possible distortions induced in the pile. The piling pressing station is under fine tuning now in firm site in order to match the final piling pressing speed of 2.5 minutes per brick.

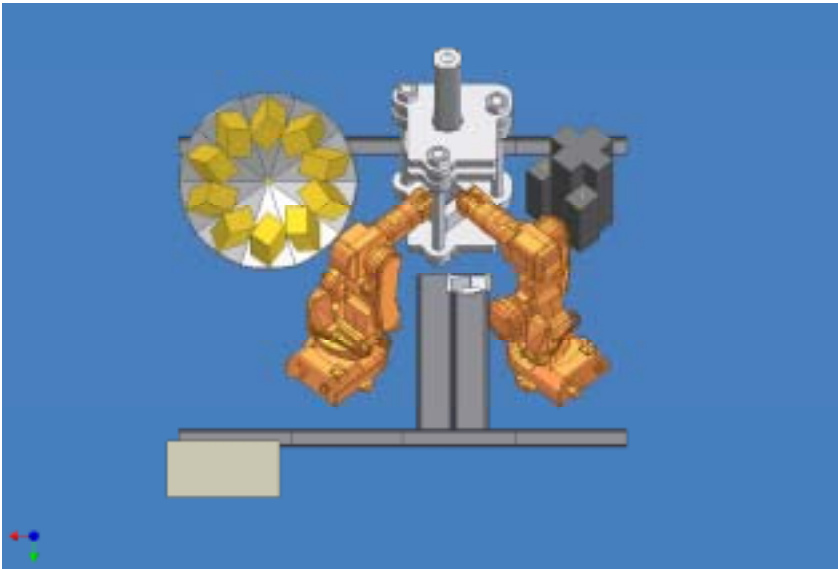


Fig 6 Final piling-pressing station layout.



Fig 7 First piling station under fine tuning

In order to match the final production speed of 1 piece each 30 seconds, the construction of additional 4 piling pressing stations has started and their delivery is expected by september 05.

Final layout of the complete BAM (see fig 8) was designed by the firm and matched with the BAM site infrastructures in collaboration with the LNGS engineers. The construction of several BAM components has started and is on schedule with respect to the official OPERA planning of activity.



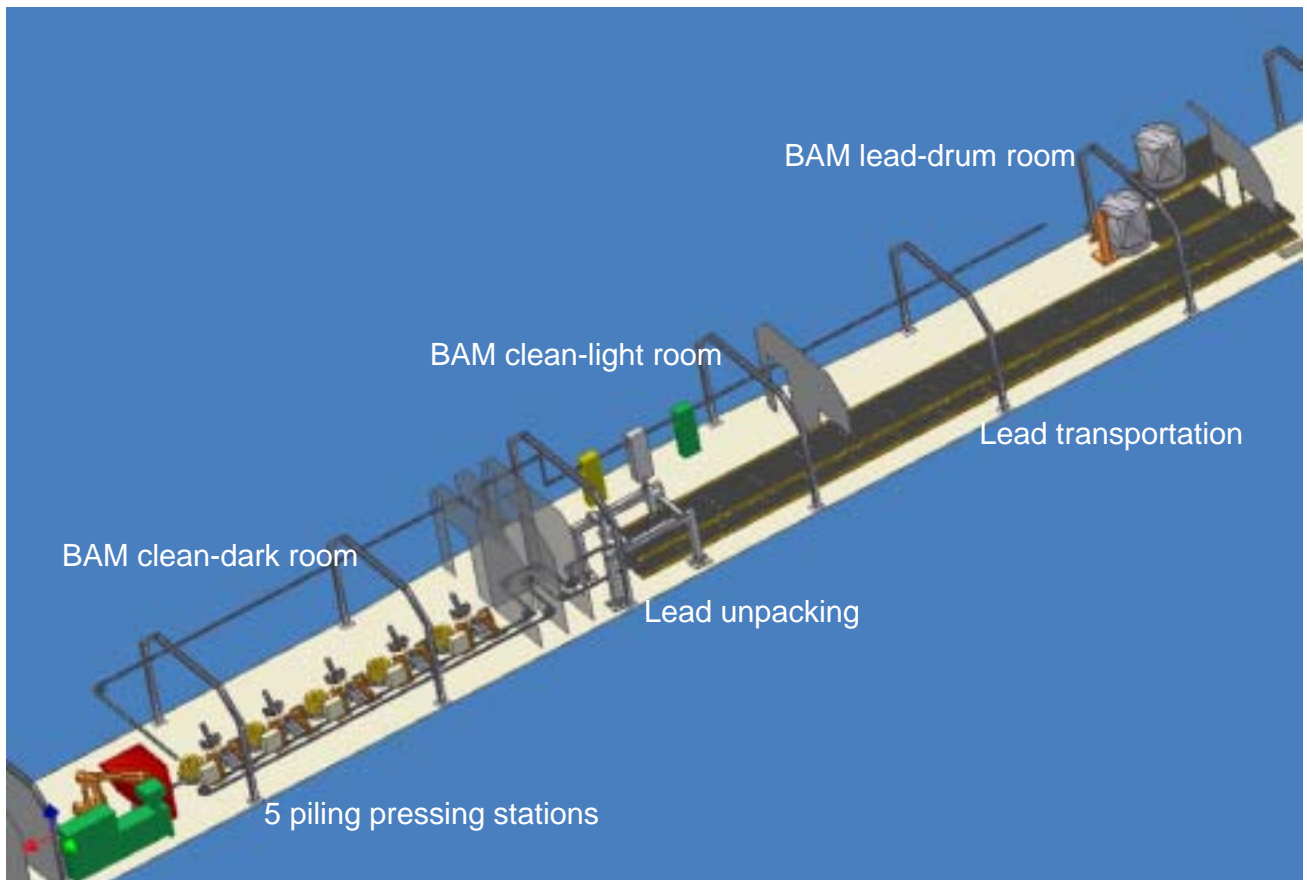


Fig.8 BAM final layout

In order to fulfill last brick changes requested to accommodate 2 CS options it was necessary to revise the Al tape wrapping method to reduce by 1mm the nominal thickness of the Al wrapped pile. The final design of the two automatic Al tape wrapping machines has been modified and concluded in June 05. Their construction has started now. The complete BAM construction is now expected by fall 05. The BAM working group is meeting regularly in the firm site each month to monitor the progress in design and construction phases and to plan and report about the validation tests being performed on real bricks with cosmic rays. All emulsion films are presently processed at CERN.

In parallel to the activity above mentioned, **the BAM site preparation in LNGS** was started. Regular monthly meetings were performed in LNGS to define the specs of all the infrastructures needed for the correct working condition of the BAM. Civil engineer, electric networking, air conditioning system, safety sensor networking were defined in close collaboration with LNGS engineers. Specs documentations were produced; tendering and ordering phases were closed. Construction phase is now in progress and



final delivery of the site is expected in summer 2005 (see fig 9-10-11 showing the starting and present conditions of the BAM LNGS site).



Fig 9-10-11 May 04, December 04 and May 05 pictures of BAM site work in progress.

Still pending problem is the possibility to use the water needed for the cooling system in the air conditioning units. In order to be independent from the LNGS commissioner activity time schedule which will define the timing and procedure to use water in underground lab, the LNGS management has promised the installation of a dedicated chiller unit to cool the air with a dedicated closed circuit system for the BAM site. Its delivery is expected in fall 05.

The BAM working group has also concluded the prototyping phase is the lead transportation box. In last year different prototypes of boxes have been constructed and tested and the final solution has been recently approved (see fig. 12). The new concept is to use plastic pallets to support a group of 56 lead sheets (one brick unit). 18 pallets are grouped in the same metal box to be transported in clean class conditions. The pallets will be used as cartridges for the BAM in order to avoid double manipulation of lead sheets.



Fig. 12 Two lead transportation box with 18 plastic pallets each.



## 4-f) Brick processing

### Overview

During the OPERA data taking, several tenth of bricks will be tagged as target modules containing triggered and reconstructed  $\nu$  events. The selected brick handling procedure includes :

- a) CS detachment and development underground,
- b) cosmic-ray exposure, brick dismantling and development at the surface lab.

At the top rate, up to about 300 bricks per week (about 18,000 individual emulsion plates) could be selected (subject to the actual beam intensity, trigger and reconstruction efficiency, and extraction strategy), extracted and then processed under high-quality standard and made available for scanning. To cope with such an unprecedented scale, a large development laboratory has been designed, featuring:

- 1) large-scale equipment for preparation, distribution, usage and disposal of the suitable chemical solutions
- 2) automated, computer-controlled multi-step development chains to be serviced in parallel mode by operators dealing with brick dismantling in safelight darkroom

### Laboratory functions in a new building

A few years ago, a new building at the Gran Sasso surface Lab has been partly designed to host special facilities for OPERA, namely :

- a) a “pit” for cosmic-ray exposures
- b) a large laboratory for brick opening and plate development in safelight darkroom (with subsidiary working space in normal light) located at the below-ground floor
- c) a large laboratory for chemical handling and preparation of the development solutions, located at the ground floor above the previous laboratory
- d) pipelines for disposal of wasted solutions into big below-ground tanks outside the building.

The construction of the new building started in summer 2004. Its completion is expected by next October.

Emulsion plates and bricks were already exposed in the Cosmic-ray pit, a cylinder of 3 m diameter with a 40 cm Fe shielding. Extensive tests are in progress to measure the spectrum and angular distribution of penetrating muons, in order to optimise the exposure time to collect a suitable integrated flux for brick inter-calibration (about 2 tracks/mm<sup>2</sup>×day).

The baseline processing method for emulsion development has been stated. However, the fine tuning of chemical composition and the time duration of the various steps is under further study in manual mode to ensure optimal scanning quality. Keeping anyway



flexibility for last-minute improvements, the equipment to provide demineralised water, to pick-up chemicals and prepare the needed solutions, to distribute them and collect wasted liquids has been defined. Some components were already delivered. Care was applied in the definition of the washing mode, one of the final steps in the development, to reduce the usage and consumption of water and mitigate the corresponding disposal load (less than 15 m<sup>3</sup>/week, compared to an initial design with 60 m<sup>3</sup>/week). The functional lay-out of the sections (preparation lab and development lab) has been designed in detail. The actual implementation is closely following the construction of the various parts of the building, such that after summer the installation of dedicated equipment will proceed in parallel with the completion of the building. The whole laboratory is expected to be ready for commissioning early in 2006, including the collection tanks for waste disposal to be provided by December 2005.

### **Automated emulsion development**

State-of-art technology was adopted for the design and construction of a multi-tank prototype chain for automated emulsion development. Six such chains will run in parallel in the steady operation mode, with a design capability of up to 10 bricks per day per chain. The processing steps will be pre-soak, development, stop, fixation, washing (multi-step) and final treatment with glycerine and surfactant. The overall duration is about 3 hours. The operation mode consists of lining-up several plate holders (one 58 plates-holder per brick) and move them timely from one step to the next by a computer. The displacement is performed by a small movable crane with a pick-up system to put/extract a holder at a given tank along the chain. The process survey and slow control is based on sensors for the crane position and status and for the in/out check of the holders at each tank station. A separate local hardware control is applied to fill-up/exhaust each tank with the corresponding chemical solution, by means of electro-valves. The number of bricks to be treated before renewal can be set software-wise. Sensors to watch the level of liquids in each tank are integrated in the slow-control.

Several tests were performed on hardware units and with the prototype. All the hardware components and the details of the actuation and control were fixed. The software for actuation and local functioning was down-loaded in the dedicated local units (PLCs) for successful test. Front-end design and cabling were defined. Presently, at the end of an extensive market search, a fraction of the components are under delivery, including connections, control boxes and cables, to allow software actuation from a remote computer and the completion of the high-level control, survey and fault-recovery software on a fully dressed single line in the next few months.

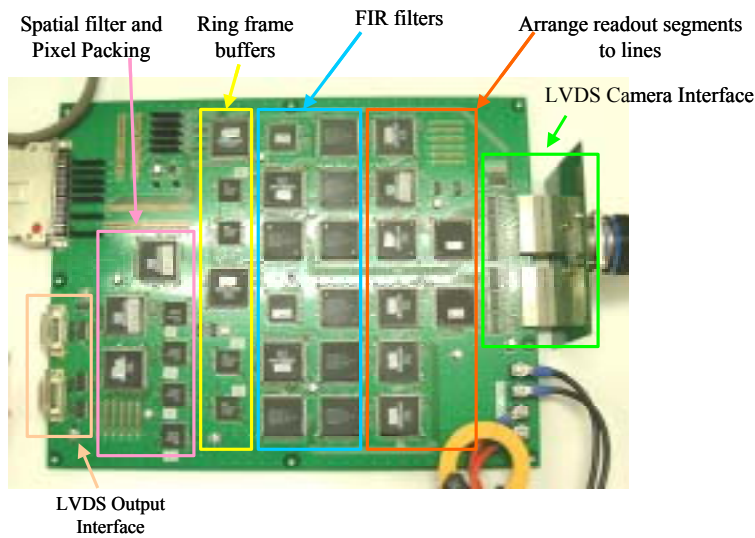
The construction of the next 5 replicas and the installation of the whole set in the laboratory will begin as soon as the new building will be delivered to users (in fact, mechanics supports will be installed even before). The check of each component in stand-alone mode will be the next step, expected to be over by the end of 2005. Test operation and real-case commissioning (i.e. with large volumes of chemicals and a large number of emulsion plates) is expected to take place early in 2006. To date, the brick processing utilities are expected to be ready and tested for the beginning of data taking with CNGS.



### 4-g: Scanning

#### Status of the S-UTS in Nagoya University

The image pre-processor is able to accept more than 3kfps which implies a peak data rate up to 1.3 Gbytes/sec. The debugging is almost completed.



Test scan have been performed at a scanning speed of  $20\text{cm}^2/\text{hour}$ , which corresponds to 30views/sec, 1/2 of design value. OPERA emulsion films stacked without lead and exposed to  $1\text{GeV}/c \pi^-$  was used for the test. Position reproducibility is shown in Fig.1. Y axis shows RMS of  $0.4\mu\text{m}$ , which is close to what can be expected by pixel and stage resolution. Non-stop tomographic image-taking is done along X axis. Larger RMS in X of  $0.6\mu\text{m}$  is because the test is done using normal stage which has not enough stability in velocity. In Fig.2, base track angle difference in 2 emulsion sheets is shown. Y axis shows RMS of  $3.1\text{mrad}$ , which is close to what is expected. Worse RMS in X axis of  $5.0 \text{ mrad}$  is again due to the stage used for the test. Pulse height distribution of base tracks is shown in Fig.3, which is similar to UTS as expected. Construction of 5 S-UTS systems is in progress.

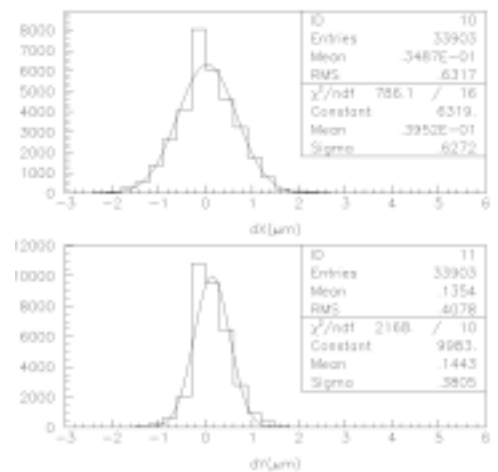


Fig.1



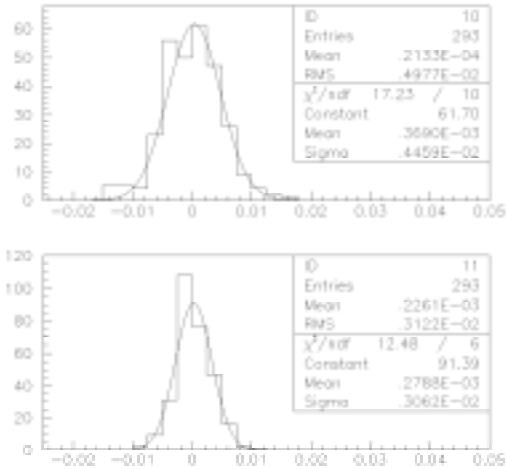


Fig.2

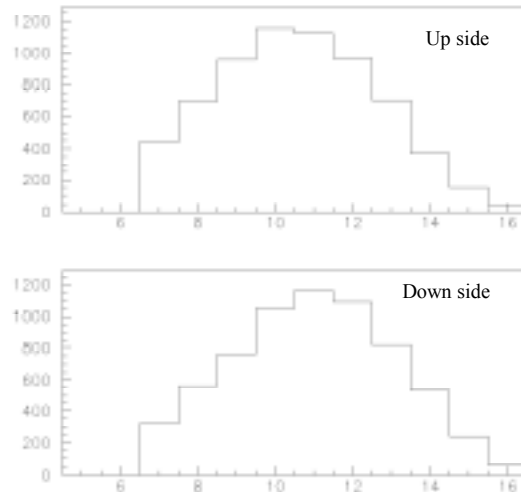
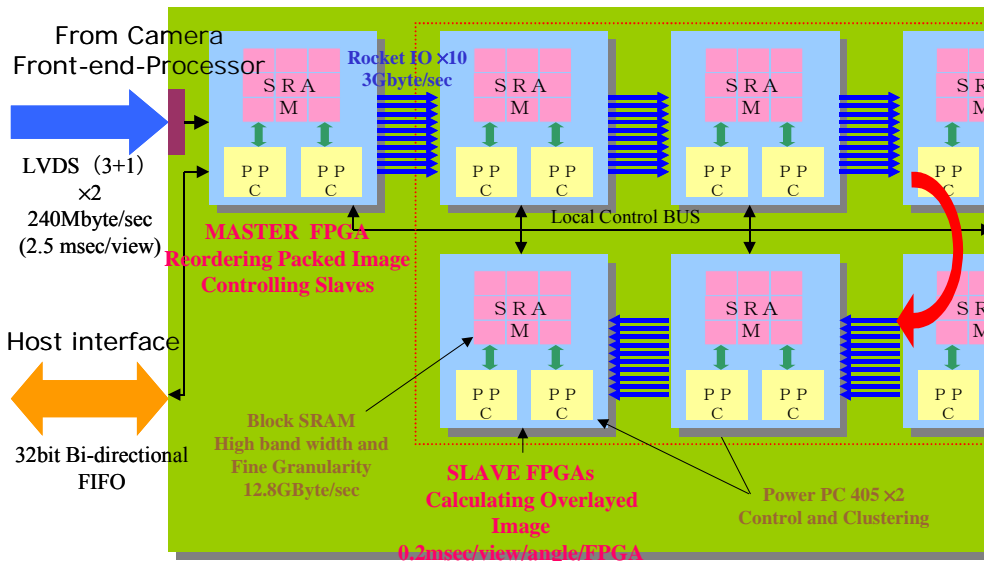


Fig.3

The remaining R&D to be completed is the new Track Recognition Processor. This processor will follow the same strategy used in the UTS (CHORUS and DONUT scanning system) and will achieve a gain of 30 in the recognition speed.



S-UTS Track Recognition Block diagram



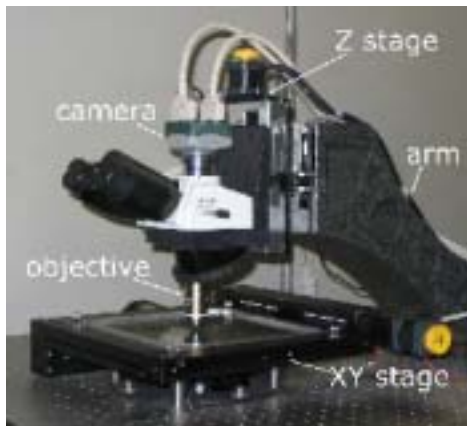
## Status of European Scanning System Project

The project aims at the development of a high-speed automatic scanning system for neutrino interaction location and reconstruction in nuclear emulsions.

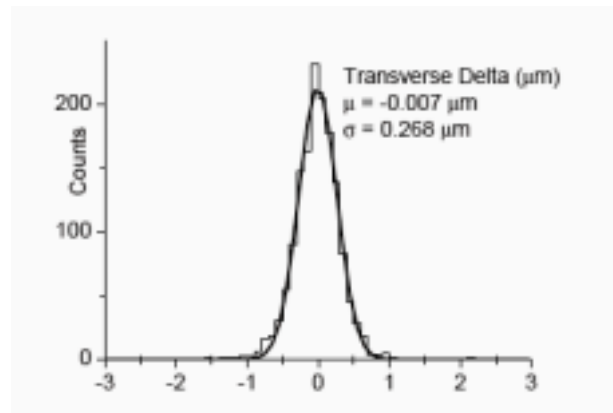
The project has been divided into two distinct phases.

**The goal of the first phase of the project**, completed at the beginning of 2004, was the development of a high-speed automatic microscope (Scan-figure 1) for the scanning of *thin* nuclear emulsions exposed to perpendicularly impinging particles, working at a speed of  $\sim 20\text{cm}^2/\text{h}$  (more than a factor of 20 better than in the past) and with sub-micron precision. The track finding efficiency is above 90% over the angular range  $[0,700]\text{mrad}$ , the instrumental background is of about  $1\text{track}/\text{cm}^2$ .

Scan-figure 2 shows the distribution of transverse position differences between base-tracks and corresponding fitted trajectories, obtained by connecting base-tracks measured in several consecutive emulsion plates. The RMS is of about 0.3 micron. The corresponding angular resolution is of about 2 mrad.



Scan-figure 1



Scan-figure 2

The various components have been industrially produced in order to replicate the system in all participating laboratories.

The microscope makes use of optical components normally employed in biological applications, adapted to work on large surfaces. A modified optical bench hosts the illumination system and is equipped with a granite bracket to sustain the optical system. The image is formed on a CMOS camera, mounted on top of the optical tube. A flat aberration-free image is obtained, resulting in a field of view of  $310 \times 390 \mu\text{m}^2$  divided into a matrix of  $1280 \times 1024$  squared pixels.

The motorized mechanical stage covers an area of  $20 \times 20 \text{cm}^2$  in the horizontal plane and a distance of a few cm's along the vertical axis. The settling time of the



horizontal XY stage is less than 80 ms for a 300 $\mu$ m-step and the positioning reproducibility is about 0.3 $\mu$ m. The speed of the vertical Z-axis depends on the camera frame rate (up to 500 fps).

Images are grabbed and processed by a programmable vision processor.

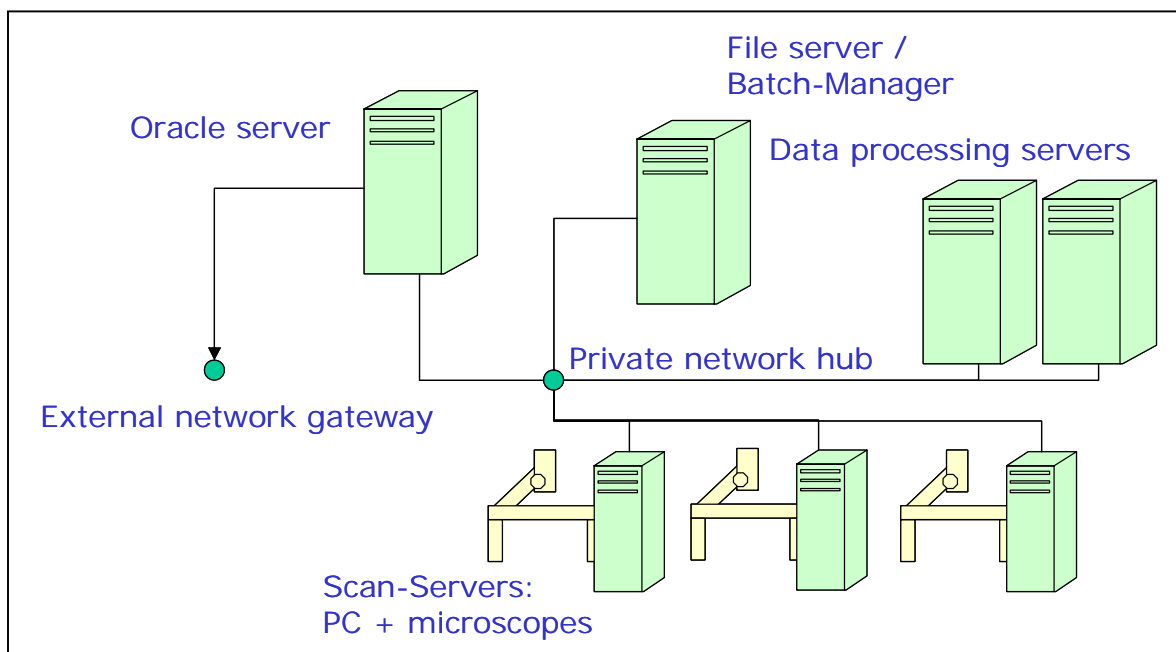
For each field of view, several images of the emulsion are taken at almost equidistant depths: an optical *tomography* is thus obtained and allows to reconstruct the trajectories of particle tracks in 3D as sequences of aligned black clusters of given size and shape *drowned* in a *sea* of background clusters.

A dedicated software controls the movements of the XY stage and the Z-axis and the image grabbing, and performs image processing and particle tracking through an asynchronous data-taking scheme that allows parallel execution of several tasks.

The European Scanning System is operational since the beginning of 2004. A total of 15 microscopes have already been installed in the INFN scanning laboratories (Bari, Bologna, LNGS, Naples, Rome, Salerno) and in the joint European laboratories (Bern, Lyon, Neuchâtel). The installation of 10 additional microscopes is underway and is expected to be completed by 2005.

A total number of 25 microscopes should be adequate to measure 15 bricks / day.

**The second phase of the project**, to be completed by the end of 2005, aims at the development of an integrated system for the online reconstruction of neutrino interactions in the OPERA target. The system consists of automatic scanning microscopes, robots for emulsion plate changing, a cluster of computing machines for online data processing, a DB-base storage system and control workstations managing scanning and online data processing tasks. The system will work on a local high-speed network.



The project requires the development of dedicated software for task management and DB data management and the upgrade of already existing software for automatic



emulsion scanning that will have to be able to take on-line decisions for the optimization of the measurement of each single event.

The system has already been designed and is currently being tested.

In parallel, studies are ongoing to define the vertex location procedure (the so-called *scan-back* procedure) and optimise the vertex reconstruction algorithms.

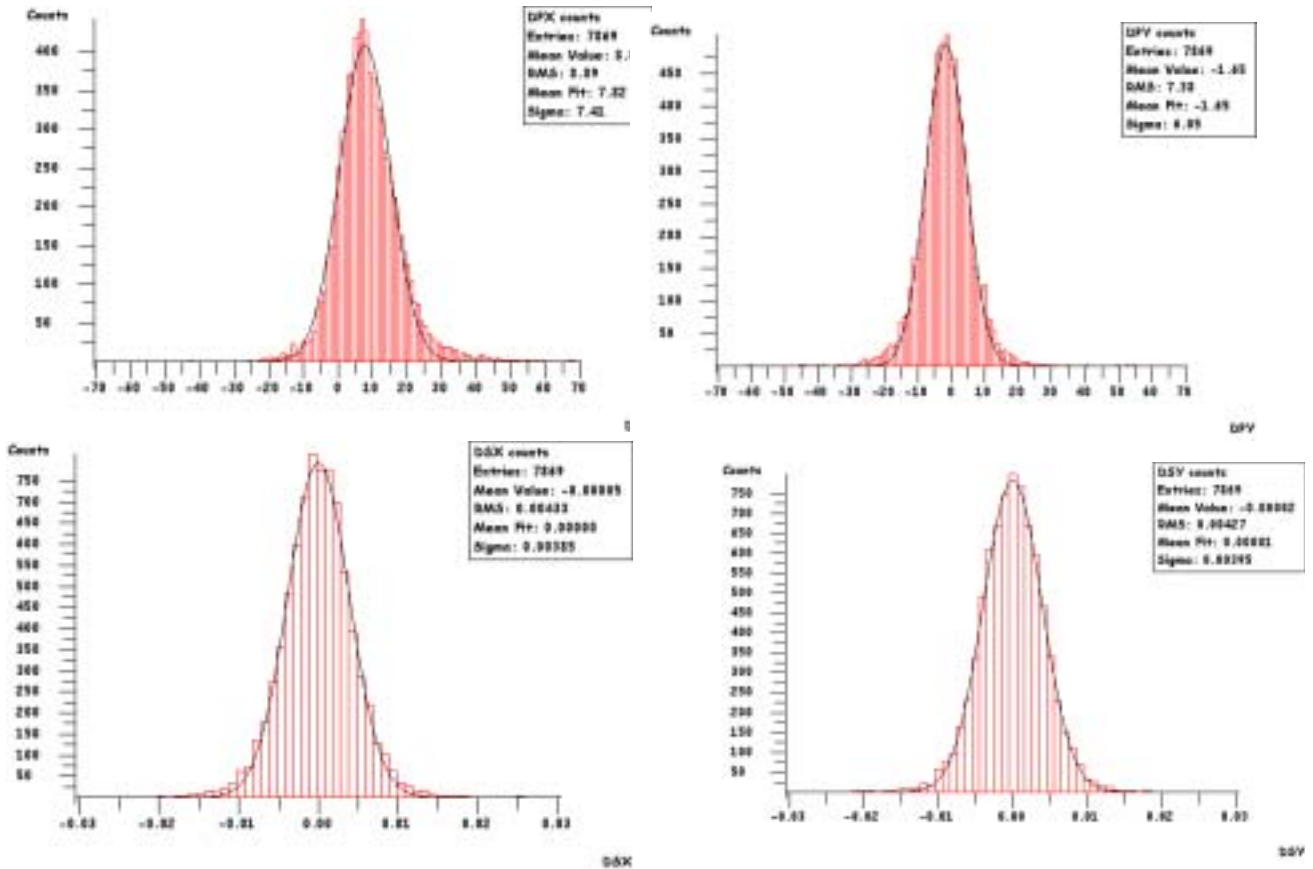


Fig. 3 shows the position and angular differences between predictions and found tracks measured in a DB-driven scan-back procedure: tracks selected in the most downstream plate of a brick exposed to 8 GeV pions (density  $\sim 0.1/\text{mm}^2$ ) have been followed-back, plate by plate, in one single microscope's view until they disappeared. The plate to plate inter-calibration has been performed by measuring three areas of  $6 \times 6 \text{ mm}^2$  in each plate and connecting cosmic ray tracks (density  $\sim 1/\text{mm}^2$ )

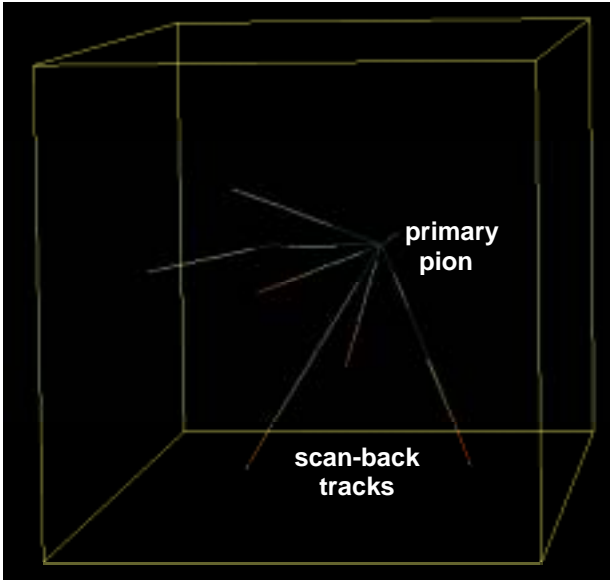
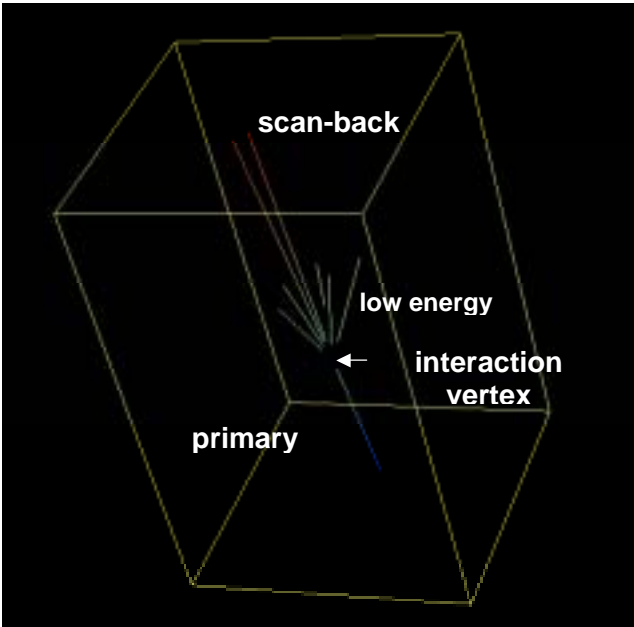


Fig. 4 shows a few vertices found in a DB-driven vertex confirmation procedure: a volume is measured around the *disappearance* point of each track in order to confirm the presence of an interaction vertex. A vertex reconstruction procedure is then applied..





## 5) Computing

The OPERA offline software is integrated in a global software framework named OpRelease, which is centrally managed at CERN on a CVS server under the CMT tool. All packages, mostly written in C++, are designed to run on the standard HEP Scientific Linux operating system.

In addition to home laboratory computing power inside the collaboration, OPERA fully uses the CERN Linux LXBATCH cluster to run its official productions. The CERN CASTOR mass storage is used to keep test beam data and official Monte-Carlo productions. For the time being OPERA uses around 1 Terabyte of data on CASTOR, out of which 600 Gigabytes for the official Monte-Carlo production of 150000 simulated events (signal and background) done from Fall 2004 to Winter 2005.

Additional computing and storage capacity are foreseen at the Gran-Sasso laboratory (LNGS); the definition of these capacities and of the associated network bandwidth from Gran Sasso to the OPERA home-labs are presently under active discussion with the LNGS authorities. **Unfortunately at the time being, we are pessimistic with respect to the capability of the LNGS to provide the needed computing support as well as for the network as for the machines and software maintenance.**

A full documentation of all the software packages below is available in detail in internal OPERA notes, and also on the Computing pages of the OPERA Web server.

### - **Simulation software used for the productions of 2004-2005 :**

Status: **Working and fully tested.**

The simulation software used for the Monte-Carlo productions of 2004-2005 consists of an event generator, NEGN, and of a particle propagation and detector simulation package, OpRoot. NEGN has been adapted from the NOMAD experiment event generator in 2001 / 2003. OpRoot has been developed from 2002 to 2004 ; it is derived from the ALICE simulation package ALIROOT and uses GEANT3 to propagate the particles and simulate their interactions. The output are hits in the detectors, and simulation of the detector online response (« digitizations ») which are interfaced with the OPERA ROOT persistent data model, OpRData.

### - **Offline Reconstruction packages :**

Status: **Working and fully tested.**

Two separate packages are necessary. The first one, FEDRA, performs the offline reconstruction of emulsion data ; starting from the microtracks it provides the base tracks, then the full tracks and the vertices and kinks. This package allows to perform the offline realignment of emulsion plates, if necessary. The second package, OpRec, performs the reconstruction of tracks inside the OPERA spectrometers and target



trackers. It contains a pattern recognition package, then a tracking package using a Kalman filter which outputs the reconstructed tracks with their momenta.

These packages are also interfaced with the OpRData persistency package ; they have been used for the official simulations of 2004-2005 described above.

- **Databases :**

Status : **Partially working ; still under development.**

OPERA will make an extensive use of relational databases for the data bookkeeping and the analysis of the experiment. Several separate local databases are under development. They will contain respectively the online information from the electronics detectors (both slow control information and event-by-event information), the information related to ECC brick manipulation and history (in the BAM, in the brick manipulator, in the development and scanning labs), and the information coming from the emulsion scanning.

The scanning database, is certainly a complicated system but the structure is already well defined (all table definitions have been agreed by European and Japanese experts in emulsions data). As a result several local scanning databases are already running without problem since months, in at least 6 European scanning labs, and contain valuable test data. The implementation in the other labs should be done in 2005. The database technology has been chosen to be ORACLE 9i. Full-scale tests of high speed simultaneous data writing and reading have been successfully performed.

The final goal is to build a global scanning database containing the relevant data coming from all individual databases of the scanning labs in Europe and Japan. The size of this main emulsion database should reach 30 to 50 Terabytes at the end of the experiment. Several replicas are envisaged to access the data from different sites. This is just a scaling of the existing databases ; all tests performed up to now do not show any indication of any technical problem.

A general OPERA database is under study, which will contain all the relevant information for final physics analysis (from electronic detectors, and from the emulsion scanning) and accessible to all physicists in the collaboration. A first working prototype is foreseen for the end of 2005.



- **Present and future developments in the Offline software :**

Status : Partially done ; some developments still under way; completion foreseen before the end of 2005.

The present simulation package OpRoot is known to have two major deficiencies for the future : it depends on an external package, ALIROOT, which is not supported anymore, and it is deemed to use only GEANT3. A new simulation package, OpSim, has been written within the framework of the « Virtual Monte Carlo » system (VMC) developed by the ROOT team mostly for the LHC experiments . This has two major advantages : the VMC will be supported during many years, and in addition the VMC provides a very convenient way to use either GEANT3, GEANT4 or FLUKA for the particle propagation and interactions.

Moreover, to get the full benefit from the VMC environment, a new OPERA geometry description package, OpGeom, has been written, based on the ROOT TGeoManager package. As a by-product, a powerful event display, OpDisplay, is now available which uses the standard ROOT display facilities.

OpSim and OpGeom have been fully tested and compared with the outputs of the previous package OpRoot. Some work remains to be done to modify the reconstruction programs to make them use the new geometry package OpGeom, which will therefore be common to all OPERA offline programs.

A further improvement will consist of taking into account the full field map of the spectrometers in the reconstruction algorithms (for the time being a constant field is assumed). This work is under way and should be finished in some months.

The overall new framework, using software tools which are common to most present HEP experiments and therefore very well tested and maintained, is expected to become the standard of OPERA before the end of 2005.

It must be noticed that all these packages have been done by a rather small team, and that manpower problems have slowed down several of the software developments described above.



## 6) General Schedule

*BAM filling SM1*      *March 06 to July 06*  
*BMS installation*      *October 05 to February 06*  
*Target1 installation*      *now to October 05*

More details, overlaps/parallelism, time slots and contingencies for each of these items on the installation critical path:

-BAM-

**the LAST day to start the filling operation is march 1st 2006**, meaning about 110 working days till the end of july, equal to 103000 bricks produced at the speed of 936 bricks a day. Contingency in this item is the fact that we do not assume to work on saturday and that we could produce more bricks a day working 10 hours or more and we are working on that. On the other hand there will be the start up phase of the BAM that will be affected both by the technical items (BAM itself) and the logistic in GS, and the BAM maintenance operations that normally are planned the saturday above mentioned. It's relevant to stress that to have the BAM running phase in march 1st, the BAM should be installed in GS on January 06 at latest, to have the pilot production of 1 day at nominal speed and analyse 100 bricks (or less?) in sampling mode out of 936 produced. Of course then the start up phase could be done in lower speed in following weeks (february), in parallel with BMS in start up phase (if ready by that time, see later -BMS-part).

For safe of clarity, on the BAM project there are still the "hot pending points" of the:

- chiller to be installed in the BAM site from GS management,
- lead (meaning availability of final quality lead, lead washing machine and lead boxes),
- CS (meaning CS packaging in GS, CS boxes production).

-BMS-

To start the BAM running phase on march 1st 06, both BMSs should be installed and commissioned by that day. Following Henri request of 4 months at most for installation and commissioning, this implies that the BMS installation should start **NOT LATER than November 1st**. We know that BMS construction at LAPP is scheduled up to sept 05. On the other hand LAPP colleagues could have some delay on the BMS construction due to unexpected technical difficulties of the item itself, and also due to present general difficult resource conditions in France. Anyway they are making all their efforts to come as early as possible in GS and at present they count to be in GS by beginning of october. In this case they could start to work immediately on the cavern side (following Bruno suggested procedure for insertion on the rail) and profit of all the experience done on that side to start and speed up the following installation on the corridor side afterward. Let's remind that the BMS on the cavern side will be fully assembled for the first time directly in GS and so it could be normal to expect a bit longer time for its installation.

Contingency on this item is , the contingency in the 4 total months given by Herri as the



longest time slot expected, the earlier start up of BMS on cavern side (with respect to November 1st latest date previously stated) and the possible increase of speed for commissioning time, thank to TDA use for target location with the help of Dario.

**-TARGET-**

at present we are going at 1 wall+ 1tt installation speed per week in steady mode. There is an agreement with both Project Leaders (Marcos and Tommaso, deputy of Alberto) and an official planning to increase the speed starting from June 27th (wall n.5) to 3walls+3TT each 2 weeks. This scenario demands for 2 days for wall and 1 day for TT. This will mean 9 working days each 2 weeks, so there is 1 day of contingency each 2 weeks. This operation will start on June 27th with wall n.5 and will demand 18 weeks (27 remaining planes/3\*2) bringing to October 21st for the end of target on SM1. (assuming no closure for LNGS in August, point still pending). Contingency on this item is the 9 days distributed on the 18 weeks and 1 week at the end. So today we assume that **Target 1 is over by the end of October** (fitting with latest date of November 1st for BMS start, even in case of no parallelism).

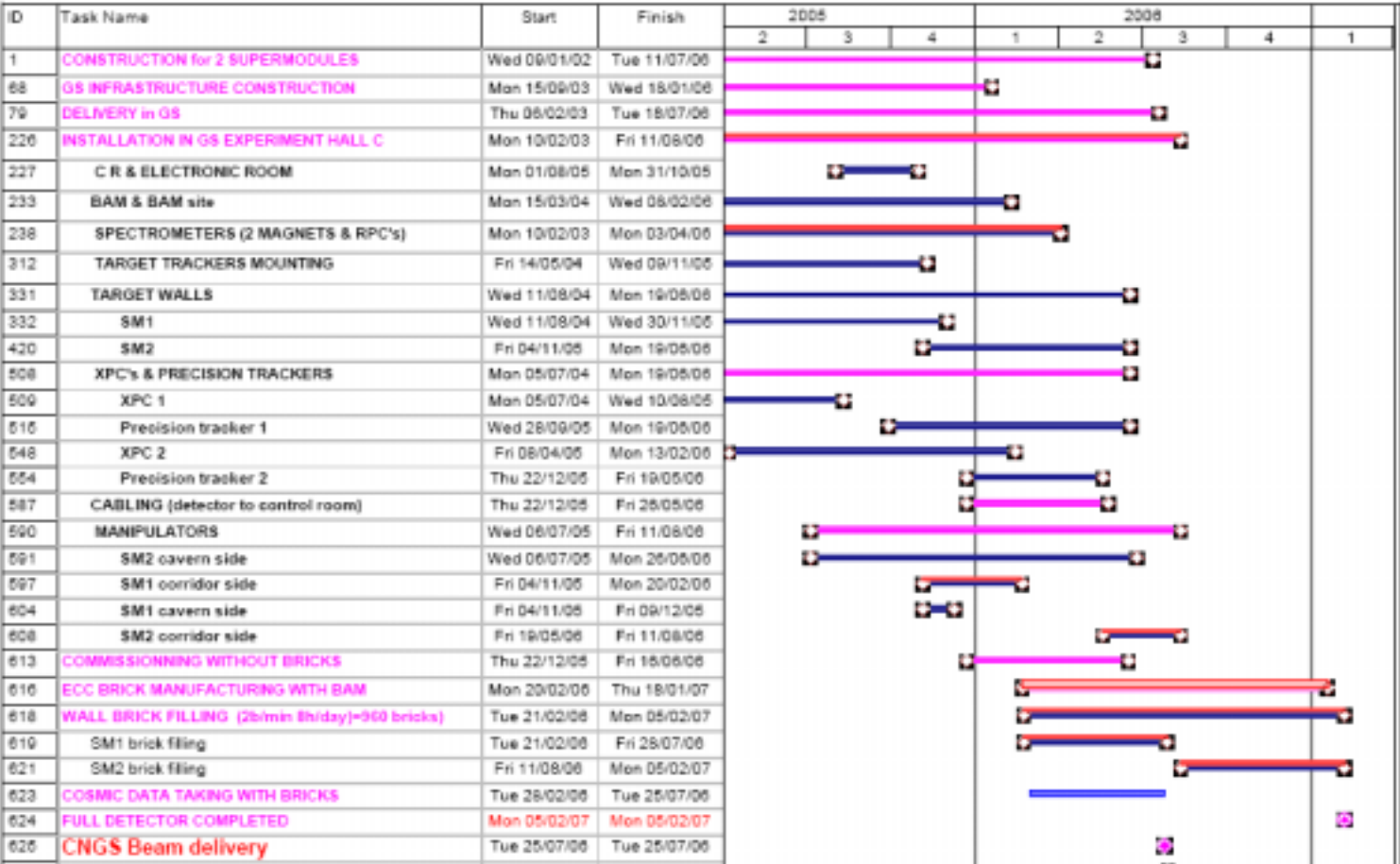
**-Target/BMS parallelism-**

It is presently under study also the possibility to minimise in October the interference between BMS/Target1 installation on the corridor side. The BMS could start asap installation and commissioning on the cavern side and go on the corridor side only after the Target1 installation is over (end of October). In this case the BMS installation on the corridor side would start and go directly on the SM1 (in serial mode after target 1 installation) avoiding temporary installation/commissioning on the SM2 corridor side (also with difficulties on the cable path) and subsequent dismounting and remounting and commissioning again of the BMS (and rails) on the SM1 (SM2). What it is still to be defined in this case is the cable path of the BMS corridor side on SM2 while being commissioned and running on SM1, being compatible with target 2 installation. LAPP colleagues are working on this point, to find a temporary alternative cable path.

Of course on top of all the items here scheduled, there will be also commissioning of spectrometers1, installation of more 4 HPT planes on SM1, XPC on SM2 and VETO, but these operations will cause "minor interferences" if they are well planned and organized, as done up to now.

On the other hand, the main point is that **we are assuming ZERO INTERFERENCES from LNGS Commissioner jobs**, and on that, unfortunately, there is no guarantee at all, as clearly stated during last Collaboration meeting.



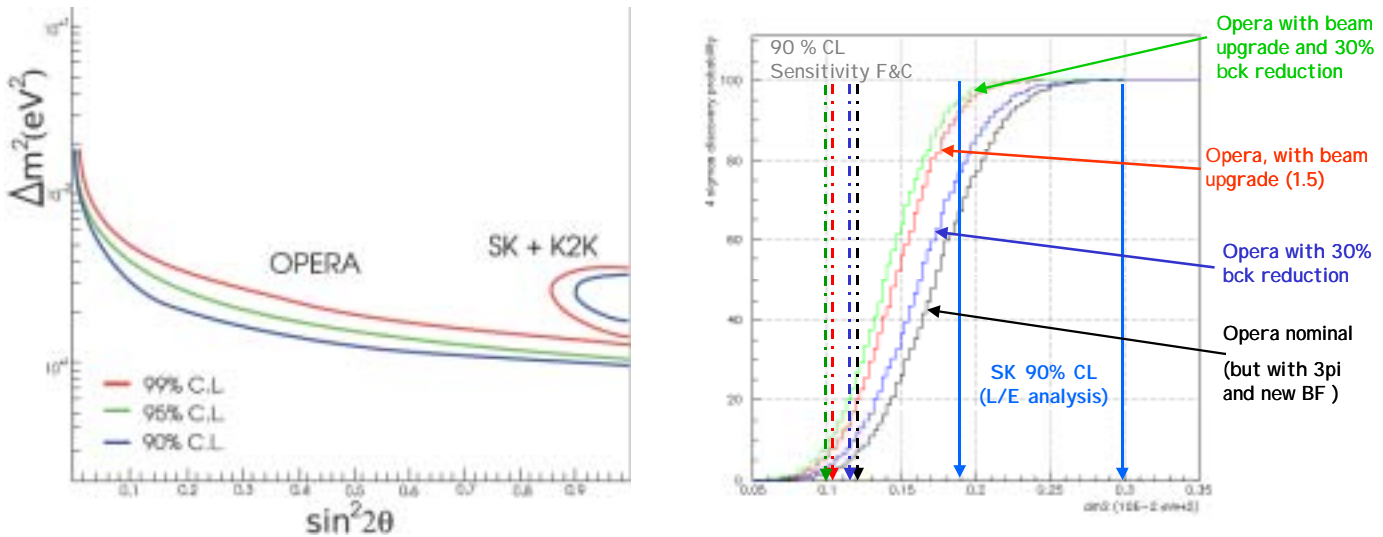




## 7) Physics performance and tests results

The OPERA physics performance have been evaluated since many years and can be summarized as follows: the combined analysis of nuclear emulsion and electronic data allows an excellent signal to background ratio. In 5 years data taking with the nominal CNGS, we expect to detect, for the best fit value of the SK data, about 13  $\tau$  decays with a background of the order of 1 event. This translates into a  $4\sigma$  discovery probability (i.e. the probability that the observed events are due to a background fluctuation is smaller than  $6.3 \times 10^{-5}$ ) of about 95% for the best fit value of the SK data. The  $4\sigma$  discovery probability for  $\Delta m^2 = 1.9 \times 10^{-3} \text{eV}^2$  and  $\Delta m^2 = 3.0 \times 10^{-3} \text{eV}^2$  (the boundary of the 90% C.L. allowed region from SK) is  $\sim 60\%$  and  $100\%$ , respectively.

In the case of no evidence for  $\nu_\mu \rightarrow \nu_\tau$  oscillations, after 5 years data taking OPERA will be able to exclude at 99% C.L. the 99% C.L. allowed region obtained by a combined fit of the SK and K2K data (see Figure).

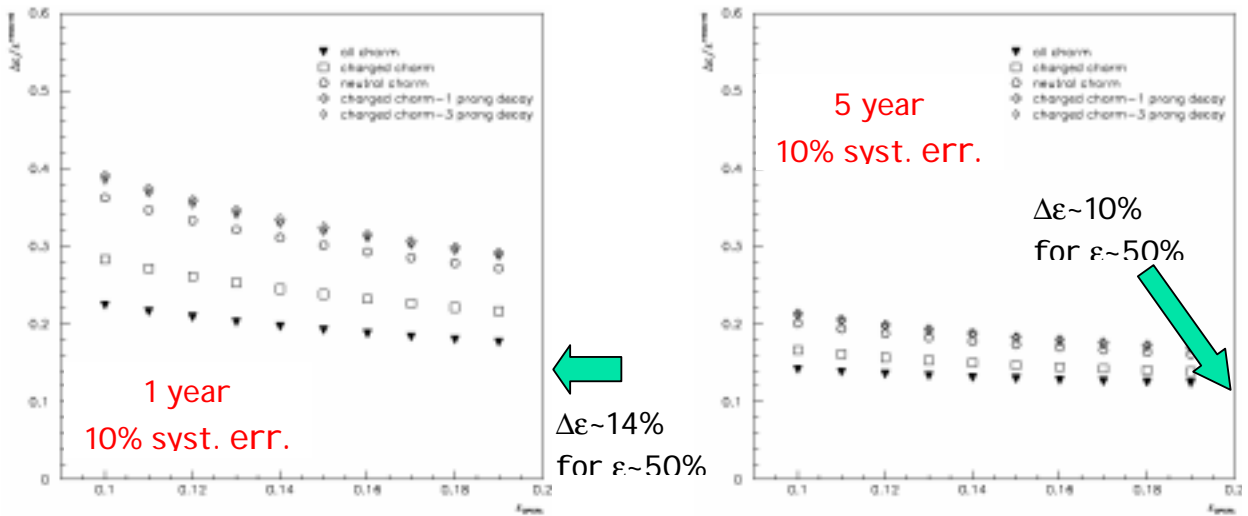


Of course, OPERA results will strongly benefit of an increase of the number of protons on targets. This topic has been discussed at length during the Villars meeting. Due to the limited statistics, a very detailed evaluation of the expected efficiencies for  $\tau$  detection is crucial for a full exploitation of the OPERA capabilities. Therefore, in the last year we mainly focused on the definition of an experimental program that grounds “rock solid” estimates of the detection efficiencies as well as of the background. In the following we briefly summarize what we achieved so far and our future plans.



**$\tau$  detection efficiency**

In neutrino charged current interactions there is a non negligible probability to produce a charmed hadron in the final state. In the case the primary muon is not identified, charmed hadron decays are one of the major sources of background. On the other hand, when the primary muon is identified, they can be compared with the expected number of events starting from the predicted neutrino flux and the charm production cross-section. The latter is being measured by the CHORUS Collaboration with accuracy of the order of 10%. Therefore, after few years of data taking, OPERA can measure the decay detection efficiency by using real data and not just Monte Carlo with an accuracy better than 20% for almost all decay topologies (see Figure).



**Charm background**

Once the decay detection efficiency is measured and the cross-section measured elsewhere, it is possible to estimate the background from charm decays. It is worth noting that in the evaluation of this background a major role is played by the muon identification ( $\mu$ ID) efficiency.

As far as the  $\mu$ ID with electronic detectors is concerned, it has been evaluated by Monte Carlo simulation and it turned out to be about 95% for primary muons in charm production, while about 80% of the  $\tau \rightarrow \mu$  are retained.

Once a decay candidate is found, we plan to make a systematic study of the ionization of all tracks produced at the primary vertex and stopping inside the target region. Given the different ionization of muons and pions before stopping, and by exploiting the emulsion capability to measure the  $dE/dx$  of charged particles, it would be possible to identify low energy muons and reject charmed hadron decays (see below).

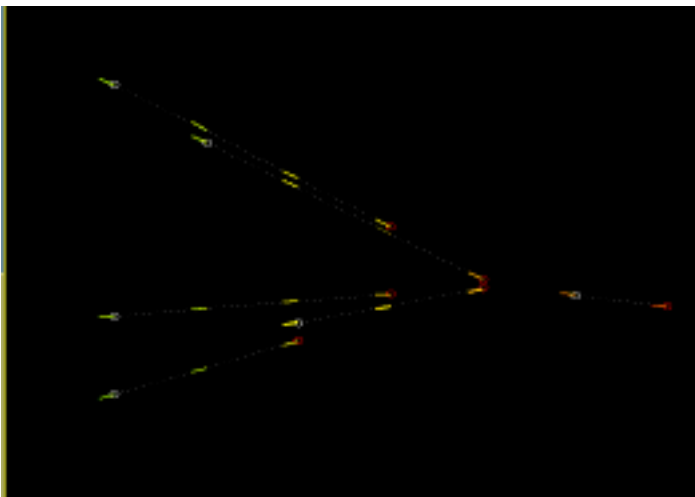


### **Hadronic background**

One of the major and unknown (there are no data on the so called “white kinks”) background is due to hadronic interactions with a decay topology. In order to measure this background we are following two strategies:

1. search for “white kink” interactions in the bricks exposed at the PS pion beam (energy going from 1 up to 10 GeV). The analysis is in progress and should be ready by the end of the year. So far, about 2000 pion interactions per energy have been detected and are under study. Two examples of pion interactions are shown in the figure;

once a real neutrino interaction is found in a brick and the search for decay topology in the fiducial volume completed, we will search for decay topologies in a volume (outside the fiducial volume) downstream from the interaction vertex. This will give us a direct measurement of the hadronic background.



*Pion multi-prong interaction*



*Pion elastic scattering*

### **Muon momentum and charge reconstruction**

Two independent programs based on a Kalman filter algorithm have been developed for the muon momentum and charge reconstruction in the spectrometer. Results are within specs. Namely, the momentum resolution is better than 30%(20%) for  $p_\mu < 20(10)$  GeV and the charge misidentification smaller than 1%. Given these performances, the muon spectrometers can be used to measure the charge and the momentum of the cosmic muons. Indeed, OPERA is one of the two largest magnetized underground detectors and, due to its larger depth, it will access a higher energy spectrum than MINOS. In order to evaluate the OPERA sensitivity, the Monte Carlo developed by the MACRO Collaboration has been implemented in our simulation and the analysis is in progress.

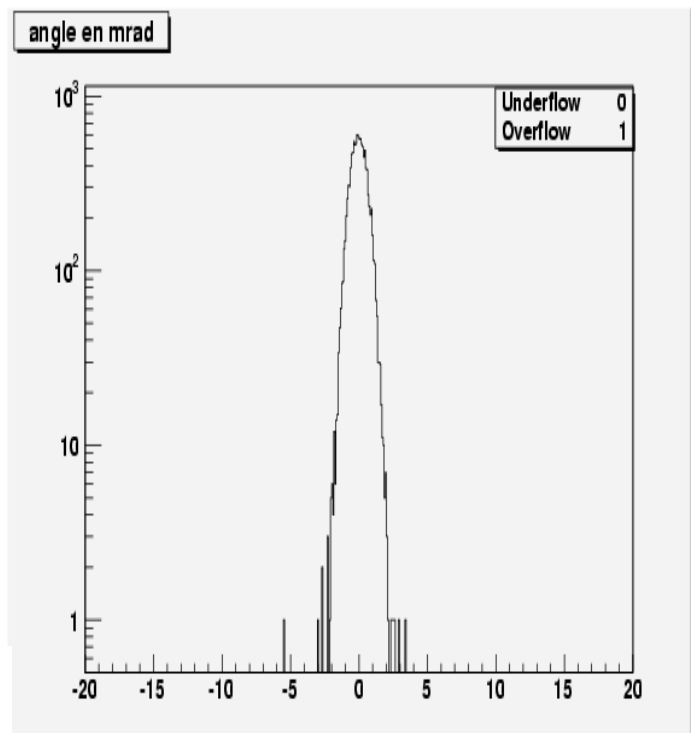


### Large angle muon scattering

The largest background in the muonic channel is given by the large angle scattering of primary muons in the lead. This process is poorly known from an experimental point of view. On the other hand, Monte Carlo calculations give an expected background for OPERA a factor 5 larger than calculations that take into account the measured form factors of the lead. Note that so far we conservatively assumed the result from the Monte Carlo calculation. Since, a previous measurement was not conclusive, a new measurement has been performed by exposing different lead thicknesses at a pure muon beam of the SPS. If the measurement confirms our previous calculations, the background in the muonic channel will reduce by about a factor 5.



*Silicon telescope put after the magnetic spectrometer*



About 70 millions of triggers were recorder of which 30 without target and 40 with various target thicknesses.

Data processing and reconstruction studies completed: Calibration, Alignment, Clusterization, rejection of multiparticle events, Tracking and vertexing

The analysis of the no-target sample shows no instrumental background and a kink angular resolution better than 0.6 mrad (the interesting events will be above 20 mrad)

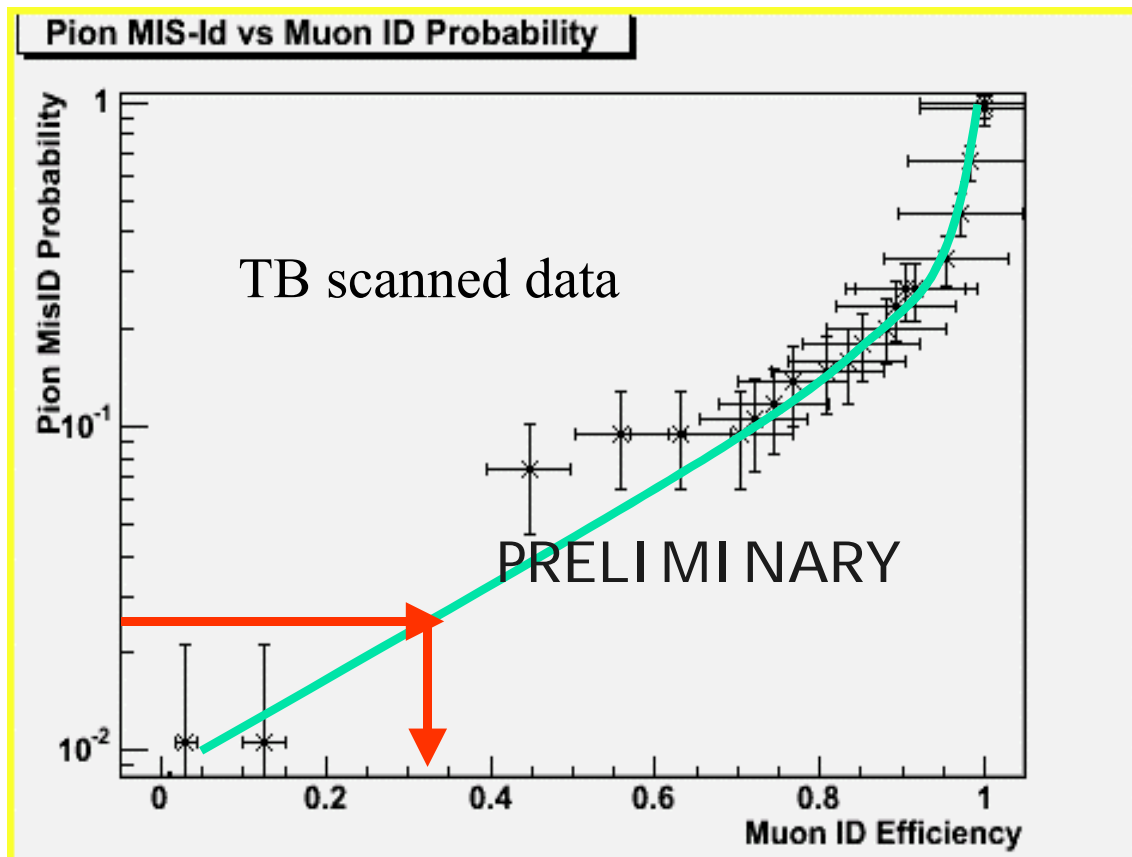




### Pion/muon separation through $dE/dx$

An important tool to strongly reduce the charm background is to exploit the different ionization ( $dE/dx$ ) of muon and pions at the end of their range. Indeed, the main source of charm background comes from charm production where the primary muon is very low energy (below 3 GeV). A series of test has been performed at the PSI, where low energy (few hundred MeV) pion and muon beams are available. Preliminary results of the data (see Figure) show that it is possible to identify about half of the muons with a pion misidentification of the order of few percent. This will allow us to reduce by about a factor of 2 the charm background with a few percent loss of the signal.

It is worth noting that the CHORUS Collaboration is measuring the total charm production cross-section with a much larger statistics and preliminary results show that it is larger (by about a factor 20-30%) than we assumed in the past. We are closely following the CHORUS analysis and we will update our results as soon as the CHORUS results will become available. Besides the ongoing analyses that should allow us to endorse our background and efficiency estimates, there are other important activities summarized in the following.

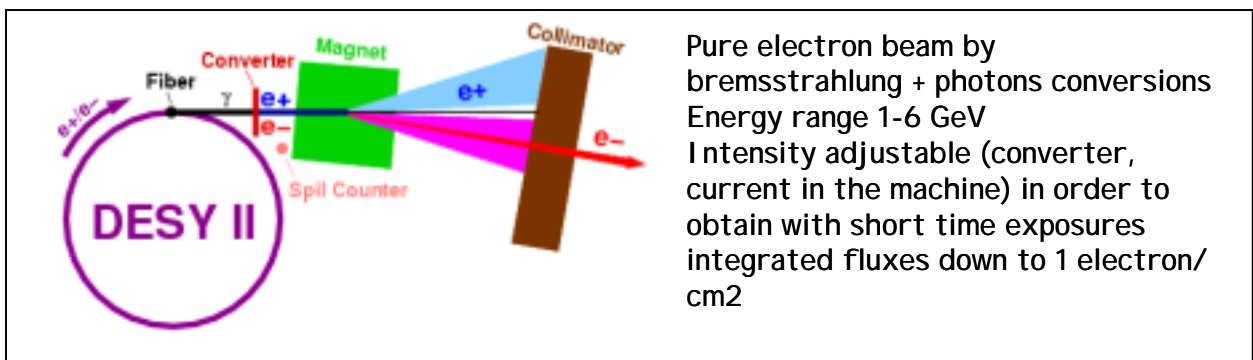




**Electron/pion separation**

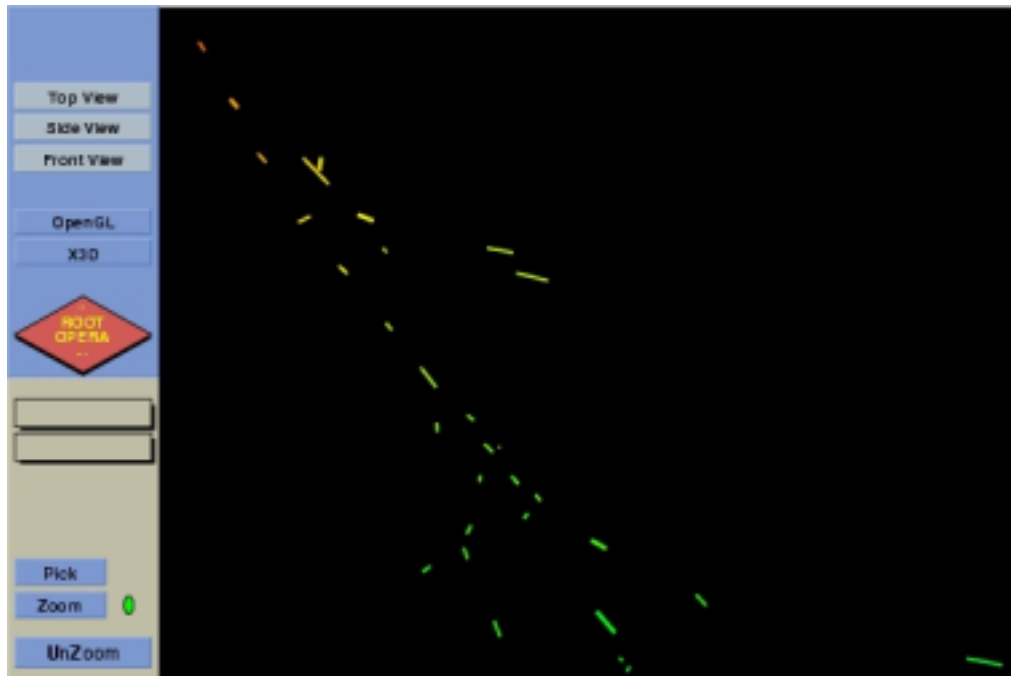
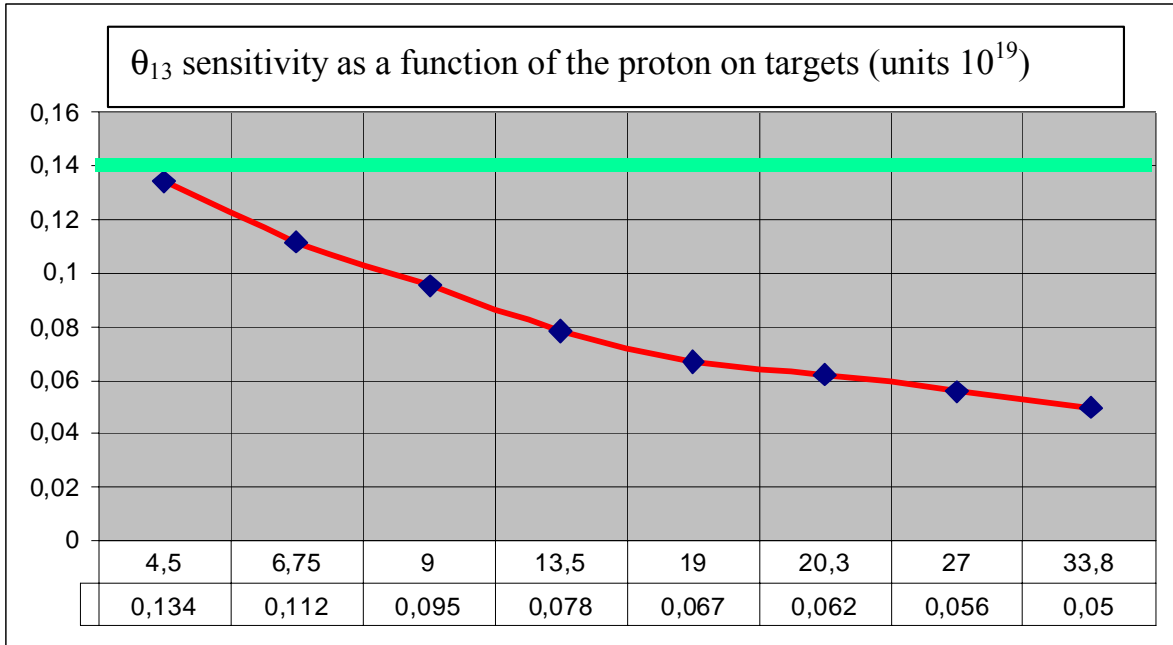
An important quantity for both  $\nu_{\mu} \rightarrow \nu_{\tau}$  and  $\nu_{\mu} \rightarrow \nu_e$  oscillations is the electron/pion separation. In order to exploit with the highest sensitivity both the oscillation channels, it would be needed to have the highest electron efficiency with the smallest pion to electron misidentification. In order to assess the potentiality of an ECC, we performed several tests with pure pion (at CERN-PS) and electron (at DESY) beams. Preliminary results show that, although the background conditions are much worse than in the real OPERA case, it is possible to reach about 90% eID (see Table 1) with a pion to electron misidentification of the order of few %. Furthermore, there is a good agreement among data and our realistic simulation of the ECC. Therefore, we are now using a simulation in the OPERA conditions in order to estimate the final eID and pion to electron misidentification.

$E$ (GeV)	$N$	$\epsilon_{e \rightarrow e}$	$\eta_{e \rightarrow \pi}$	$\epsilon_{NC}$
1	422	0.86	0.07	0.08
3	965	0.92	0.06	0.02
6	666	0.95	0.04	0.01





Given the very good efficiency of the ECC technique in identifying electrons and discriminating electrons from  $\pi^0$ , we expect to improve substantially the present CHOOZ limit on  $\nu_\mu \rightarrow \nu_e$  oscillations. After 5 years we expect to explore, at 90% C.L.,  $\theta_{13}$  values down to about  $7^\circ$ . Of course, the OPERA sensitivity to  $\theta_{13}$  being limited by the statistics, strongly depends on the number of proton on targets





### **CNGS beam monitoring**

A full simulation of all the rock surrounding the detector and of the Borexino tanks has been developed in order to evaluate the accuracy we can reach in the monitoring of the neutrino beam. About 100 muons/day produced in neutrino charged current interactions cross the whole detectors. 80% of those muons are detected, while only for 50% of them the charge and the momentum are reconstructed. This means that in few days it is possible to have a check of the beam with 10% accuracy. Note that having the possibility to measure the charge of the muon is particularly important since it will give us the possibility to measure the  $\nu_\mu/\text{anti-}\nu_\mu$  ratio. Furthermore, having access to the high-energy part of the spectrum, allows us to monitor  $\nu$  coming from K, being the latter the main source of the  $\nu_e$  contamination of the beam.



## 8) Funding Issues

	Cost	Cont.	Belgium	Croatia	France	Germany	Italy	Japan	Russia	Switzer.	Total contributions	
	M€	M€	**		**	**			***		Available	Missing
<b>Target</b>												
Emulsion tooling	0.68							0.68			0.68	
Lead plates *	4.60	0.40	0.07		0.30	0.75	3.78			0.10	5.00	
Brick Assembly Machine	1.77	0.16					1.79	0.14			1.93	
Wall mechanics	1.54	0.14					1.68				1.68	
Trackers *	2.78	0.19	0.61	0.01	1.55				0.05	0.75	2.97	
Tracker PMTs	1.50						1.50				1.50	
<b>Sub total</b>	<b>12.87</b>	<b>0.89</b>										
<b>Muon tagging + momentum</b>												
Magnets	3.48						3.48				3.48	
RPCs and XPC	1.46	0.13					1.59				1.59	
Drift Tubes	1.83	0.27				2.05			0.05		2.10	
Veto	0.29	0.03					0.32				0.32	
<b>Sub total</b>	<b>7.06</b>	<b>0.43</b>										
<b>Infrastructure</b>												
General structure	0.63	0.06					0.69				0.69	
Brick handling machine	0.43	0.04			0.47						0.47	
DAQ, network, SC	0.38	0.04			0.42						0.42	
Ass. Tools, survey, transp.	0.48	0.04					0.52				0.52	
Cabling	0.33	0.03					0.36				0.36	
<b>Sub total</b>	<b>2.25</b>	<b>0.21</b>										
<b>Total</b>	<b>22.18</b>	<b>1.53</b>										
<b>Emulsion films</b>	<b>26.36</b>							26.36			26.36	
<b>Emulsion processing</b>	<b>0.20</b>						0.20				0.20	
<b>Emulsion readout</b>	<b>8.21</b>				0.26	0.20	3.50	4.08		0.17	8.21	
<b>Ext. manpower</b>	<b>0.90</b>	<b>0.11</b>					1.01				1.01	
<b>Grand total</b>	<b>57.86</b>	<b>1.64</b>	<b>0.68</b>	<b>0.01</b>	<b>3.00</b>	<b>3.00</b>	<b>20.42</b>	<b>31.26</b>	<b>0.10</b>	<b>1.02</b>	<b>59.49</b>	<b>0.00</b>



9) Human resource issue